



Type 441 DIN 442 DIN

Flanged Safety Relief Valves
– spring loaded

US Units



Facts

LESER

The-Safety-Valve.com

Type 441, 442 DIN

LESER

Conventional design

Type 441, 442 DIN

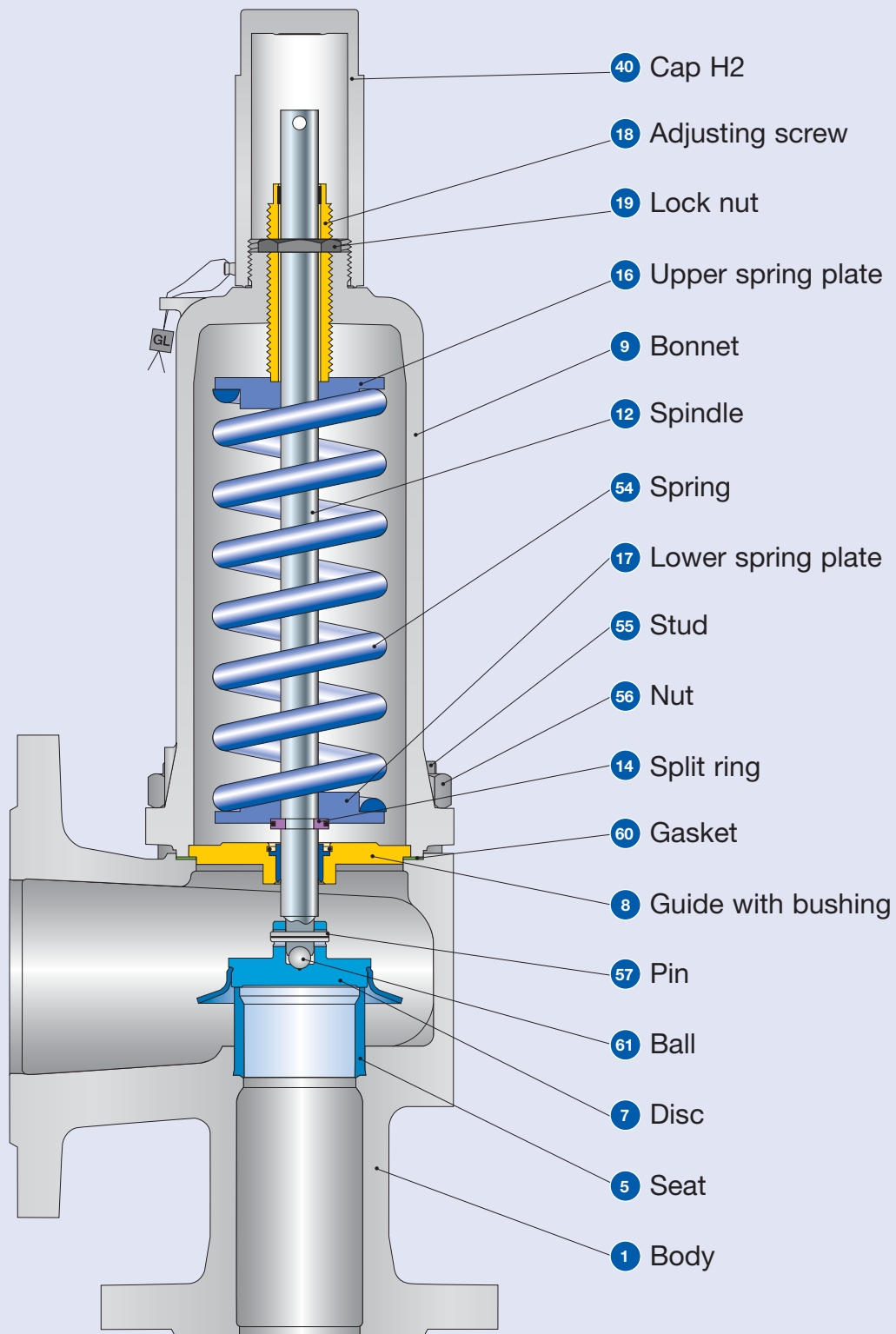

Conventional design

Materials					
Item	Component	Type 4411 / 4421 DIN	Type 4415 / 4425 DIN	Type 4412 / 4422 DIN	Type 4414 DIN
1	Body	0.6025	0.7043	1.0619	1.4408
		Cast iron	Ductile Gr. 60-40-18	SA 216 WCB	SA 351 CF8M
5	Seat	1.4404	1.4404	1.4404	1.4404
		316L	316L	316L	316L
7	Disc	1.4122	1.4122	1.4122	1.4404
		Hardened stainless steel	Hardened stainless steel	Hardened stainless steel	316L
8	Guide with bushing	1.4104, 1.0501, 0.7040	1.4104, 1.0501, 0.7040	1.4104, 1.0501, 0.7040	1.4404
		Chrome or carbon steel	Chrome or carbon steel	Chrome or carbon steel	316L
		1.4104 tenifer	1.4104 tenifer	1.4104 tenifer	–
		Chrome steel tenifer	Chrome steel tenifer	Chrome steel tenifer	–
9	Bonnet	0.7040, 0.7043, 1.0619	0.7040, 0.7043, 1.0619	0.7040, 0.7043, 1.0619	1.4408, 1.4404, 1.4571
		Ductile Gr. 60-40-18, SA 216 WCB	Ductile Gr. 60-40-18, SA 216 WCB	Ductile Gr. 60-40-18, SA 216 WCB	SA 351 CF8M, SA 479 316L, SA 479 316Ti
12	Spindle	1.4021	1.4021	1.4021	1.4404
		420	420	420	316L
14	Split ring	1.4104	1.4104	1.4104	1.4404
		Chrome steel	Chrome steel	Chrome steel	316L
16/17	Spring plate	1.0718	1.0718	1.0718	1.4404
		Steel	Steel	Steel	316L
18	Adjusting screw with bushing	1.4104 PTFE	1.4104 PTFE	1.4104 PTFE	1.4404 PTFE
		Chrome steel PTFE	Chrome steel PTFE	Chrome steel PTFE	316L PTFE
19	Lock nut	1.0718	1.0718	1.0718	1.4404
		Steel	Steel	Steel	316L
40	Cap H2	1.0718 or 0.7043	1.0718 or 0.7043	1.0718 or 0.7043	1.4404
		12L13 or Gr. 60-40-18	12L13 or Gr. 60-40-18	12L13 or Gr. 60-40-18	316L
54	Spring standard	1.1200, 1.8159, 1.7102	1.1200, 1.8159, 1.7102	1.1200, 1.8159, 1.7102	1.4310
		Carbon steel	Carbon steel	Carbon steel	Stainless steel
	Spring optional	1.4310	1.4310	1.4310	–
		Stainless steel	Stainless steel	Stainless steel	–
55	Stud	1.1181	1.1181	1.1181	1.4401
		Steel	Steel	Steel	B8M
56	Nut	1.0501	1.0501	1.0501	1.4401
		2H	2H	2H	8M
57	Pin	1.4310	1.4310	1.4310	1.4310
		Stainless steel	Stainless steel	Stainless steel	Stainless steel
60	Gasket	Graphite / 1.4401	Graphite / 1.4401	Graphite / 1.4401	Graphite / 1.4401
		Graphite / 316	Graphite / 316	Graphite / 316	Graphite / 316
61	Ball	1.3541	1.3541	1.3541	1.4401
		Hardened stainless steel	Hardened stainless steel	Hardened stainless steel	316

Please notice:

- Modifications reserved by LESER
- If several materials are specified LESER defines the material.
- LESER can upgrade materials without notice.
- Every part can be replaced by other material acc. to customer specification.

Type 441, 442 DIN

LESER

Balanced bellows design

Type 441, 442 DIN

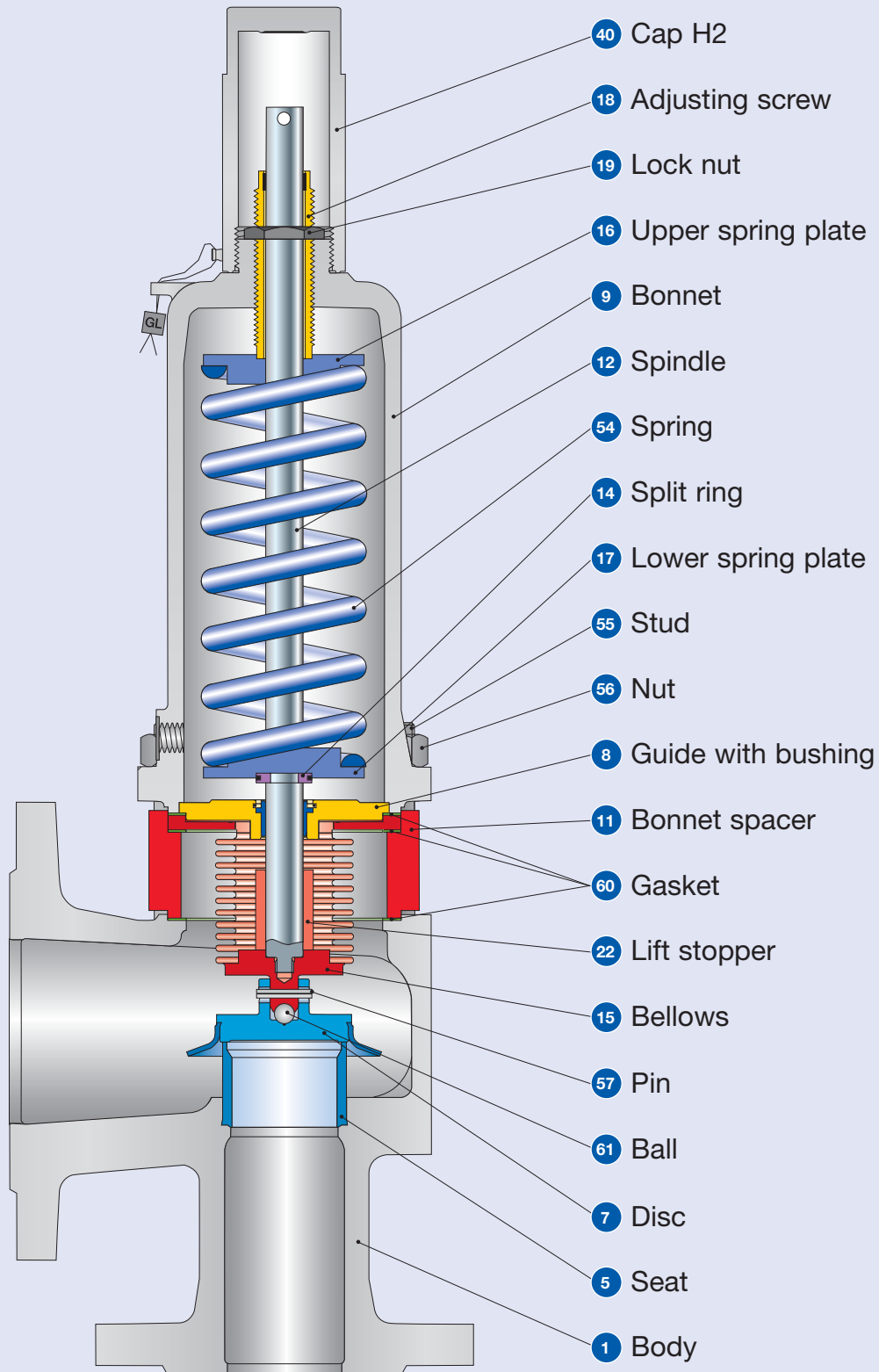

Balanced bellows design

Materials					
Item	Component	Type 4411 / 4421 DIN	Type 4415 / 4425 DIN	Type 4412 / 4422 DIN	Type 4414 DIN
1	Body	0.6025	0.7043	1.0619	1.4408
		Cast iron	Ductile Gr. 60-40-18	SA 216 WCB	SA 351 CF8M
5	Seat	1.4404	1.4404	1.4404	1.4404
		316L	316L	316L	316L
7	Disc	1.4122	1.4122	1.4122	1.4404
		Hardened stainless steel	Hardened stainless steel	Hardened stainless steel	316L
8	Guide with bushing	1.4104, 1.0501, 0.7040	1.4104, 1.0501, 0.7040	1.4104, 1.0501, 0.7040	1.4404
		Chrome or carbon steel	Chrome or carbon steel	Chrome or carbon steel	316L
		1.4104 tenifer	1.4104 tenifer	1.4104 tenifer	-
		Chrome steel tenifer	Chrome steel tenifer	Chrome steel tenifer	-
9	Bonnet	0.7040, 0.7043, 1.0619	0.7040, 0.7043, 1.0619	0.7040, 0.7043, 1.0619	1.4408, 1.4404, 1.4571
		Ductile Gr. 60-40-18, SA 216 WCB	Ductile Gr. 60-40-18, SA 216 WCB	Ductile Gr. 60-40-18, SA 216 WCB	SA 351 CF8M, SA 479 316L, SA 479 316Ti
11	Bonnet spacer	1.0460	1.0460	1.0460	1.4404
		Carbon steel	Carbon steel	Carbon steel	316L
12	Spindle	1.4404	1.4404	1.4404	1.4404
		316L	316L	316L	316L
14	Split ring	1.4104	1.4104	1.4104	1.4404
		Chrome steel	Chrome steel	Chrome steel	316L
15	Bellows	1.4571	1.4571	1.4571	1.4571
		316Ti	316Ti	316Ti	316Ti
16/17	Spring plate	1.0718	1.0718	1.0718	1.4404
		Steel	Steel	Steel	316L
18	Adjusting screw with bushing	1.4104 PTFE	1.4104 PTFE	1.4104 PTFE	1.4404 PTFE
		Chrome steel PTFE	Chrome steel PTFE	Chrome steel PTFE	316L PTFE
19	Lock nut	1.0718	1.0718	1.0718	1.4404
		Steel	Steel	Steel	316L
22	Lift stopper	1.4404	1.4404	1.4104	1.4404
		316L	316L	Chrome steel	316L
40	Cap H2	1.0718 or 0.7043	1.0718 or 0.7043	1.0718 or 0.7043	1.4404
		12L13 or Gr. 60-40-18	12L13 or Gr. 60-40-18	12L13 or Gr. 60-40-18	316L
54	Spring standard	1.1200, 1.8159, 1.7102	1.1200, 1.8159, 1.7102	1.1200, 1.8159, 1.7102	1.4310
		Carbon steel	Carbon steel	Carbon steel	Stainless steel
54	Spring optional	1.4310	1.4310	1.4310	-
		Stainless steel	Stainless steel	Stainless steel	-
55	Stud	1.4401	1.4401	1.4401	1.4401
		B8M	B8M	B8M	B8M
56	Nut	1.4401	1.4401	1.4401	1.4401
		8M	8M	8M	8M
57	Pin	1.4310	1.4310	1.4310	1.4310
		Stainless steel	Stainless steel	Stainless steel	Stainless steel
60	Gasket	Graphite / 1.4401	Graphite / 1.4401	Graphite / 1.4401	Graphite / 1.4401
		Graphite / 316	Graphite / 316	Graphite / 316	Graphite / 316
61	Ball	1.3541	1.3541	1.3541	1.4401
		Hardened stainless steel	Hardened stainless steel	Hardened stainless steel	316

Please notice:

- Modifications reserved by LESER
- If several materials are specified LESER defines the material.
- LESER can upgrade materials without notice.
- Every part can be replaced by other material acc. to customer specification.

How to order – Article numbers

Article numbers															
			DN _I	20	20	25	32	40	50	65	80	100	125	150	200
			DN _O	32	40	40	50	65	80	100	125	150	200	250	300
			Actual Orifice diameter d ₀ [mm]	18	18	23	29	37	46	60	74	92	98	125	165
			Actual Orifice area A ₀ [mm ²]	254	254	416	661	1075	1662	2827	4301	6648	7543	12272	21382
Body material: 0.6025 (cast iron)															
Bonnet closed	H2	Art.-No. 4411.	4372	–	4382	4392	4402	4412	4422	4432	4442	4452	4462	–	
	H3	Art.-No. 4411.	4373	–	4383	4393	4403	4413	4423	4433	4443	4453	–	–	
	H4	Art.-No. 4411.	4374	–	4384	4394	4404	4414	4424	4434	4444	4454	4464	–	
open	H3	Art.-No. 4421.	4375	–	4385	4395	4405	4415	4425	4435	4445	4455	4465	–	
Body material: 0.7043 (ductile Gr. 60-40-18)															
Bonnet closed	H2	Art.-No. 4415.	–	–	7382	7392	7402	7412	7422	7432	7442	7452	7462	7472	
	H3	Art.-No. 4415.	–	–	7383	7393	7403	7413	7423	7433	7443	7453	–	–	
	H4	Art.-No. 4415.	–	–	7384	7394	7404	7414	7424	7434	7444	7454	7464	7474	
open	H3	Art.-No. 4425.	–	–	7385	7395	7405	7415	7425	7435	7445	7455	7465	7475	
Body material: 1.0619 (WCB)															
Bonnet closed	H2	Art.-No. 4412.	–	4502	4512	4522	4532	4542	4552	4562	4572	4582	4592	4612	
	H3	Art.-No. 4412.	–	4503	4513	4523	4533	4543	4553	4563	4573	4583	–	–	
	H4	Art.-No. 4412.	–	4504	4514	4524	4534	4544	4554	4564	4574	4584	4594	4614	
open	H3	Art.-No. 4422.	–	4505	4515	4525	4535	4545	4555	4565	4575	4585	4595	4615	
Body material: 1.4408 (CF8M)															
Bonnet closed	H2	Art.-No. 4414.	–	–	4642	4652	4662	4672	4682	4692	4702	4712	4722	–	
	H4	Art.-No. 4414.	–	–	4644	4654	4664	4674	4684	4694	4704	4714	4724	–	

Dimensions and weights

US Units													
	DN _i	20	20	25	32	40	50	65	80	100	125	150	200
	DN _o	32	40	40	50	65	80	100	125	150	200	250	300
	Actual Orifice diameter d ₀ [inch]	0.71	0.71	0.91	1.14	1.46	1.81	2.36	2.91	3.62	3.86	4.92	6.5
	Actual Orifice area A ₀ [inch ²]	0.394	0.394	0.644	1.024	1.667	2.576	4.383	6.666	10.304	11.691	19.021	33.142
Weight		20	20	20	26	35	49	71	123	165	187	289	628
[lbs]	with bellows	21	21	21	28	38	52	79	132	183	205	313	637
Center to face	Inlet a	3 11/32	3 11/32	4 1/8	4 17/32	5 16/32	5 29/32	6 11/16	7 11/16	8 21/32	9 27/32	11 7/32	11 13/32
[inch]	Outlet b	3 3/4	3 3/4	3 15/16	4 11/32	4 17/32	4 23/32	5 16/32	6 5/16	7 3/32	7 7/8	8 27/32	11 13/16
Height (H4)	Standard H max.	11 13/16	11 13/16	13 11/32	17 9/16	20 5/32	22 13/32	27 17/32	31 17/32	34 3/4	35 15/16	42 5/8	54 11/32
[inch]	Bellows H max.	13 9/32	13 9/32	14 7/8	19 7/32	21 21/32	24 7/32	30 9/32	33 27/32	36 31/32	38 5/32	45	54 11/32
Support brackets	A									10 29/32	10 29/32	12 19/32	19 19/32
[inch]	B									6 1/4	6 1/4	7 9/32	1)
(drilled only on request)	C									Ø 3/4	Ø 3/4	Ø 3/4	Ø 3/4
	D									11 17/32	12 17/32	15 7/16	1)
	E									26/32	26/32	1 3/32	1)

Type 441, 442 DIN

Body material: 0.6025 (cast iron)				
DIN Flange²⁾	Inlet	PN 16	–	PN 16
	Outlet	PN 16	–	PN 16
Body material: 0.7043 (ductile Gr. 60-40-18)				
DIN Flange²⁾	Inlet	–	–	PN 40
	Outlet	–	–	PN 16
Body material: 1.0619 (WCB)				
DIN Flange²⁾	Inlet	–	–	PN 40
	Outlet	–	–	PN 16
Body material: 1.4408 (CF8M)				
DIN Flange²⁾	Inlet	–	–	PN 40
	Outlet	–	–	PN 16

1)

Body material	B	D	E
	[inch]	[inch]	[inch]
0.6025	5 29/32	11 13/32	5/8
0.7043	5 29/32	11 17/32	13/16
1.0619	6 1/4	11 17/32	13/16
1.4408	5 29/32	11 17/32	13/16

2) Standard flange rating. For other flange drillings and facings please refer to page 01/16 and 01/17.

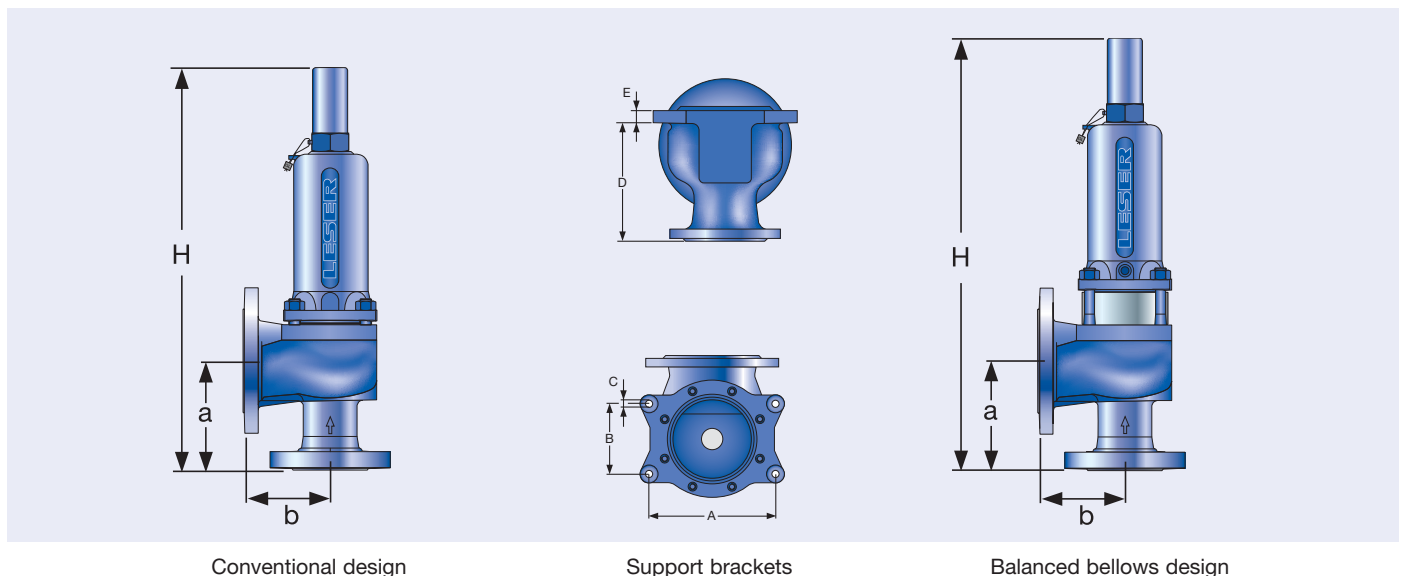

Pressure temperature ratings

US Units

	DN _I	20	20	25	32	40	50	65	80	100	125	150	200	
	DN _O	32	40	40	50	65	80	100	125	150	200	250	300	
Actual Orifice diameter d ₀ [inch]		0.71	0.71	0.91	1.14	1.46	1.81	2.36	2.91	3.62	3.86	4.92	6.5	
Actual Orifice area A ₀ [inch ²]		0.394	0.394	0.644	1.024	1.667	2.576	4.383	6.666	10.304	11.691	19.021	33.142	
Body material: 0.6025 (cast iron)														
DIN Flange	Inlet	PN 16	-	PN 16										-
	Outlet	PN 16	-	PN 16										-
Minimum set pressure	p [psig] S/GL	1.5	-	1.5	1.5	1.5	1.5	1.5	1.5	1.5	1.5	1.5	-	
Min. set pressure¹⁾ standard bellows	p [psig] S/GL	43.5	-	43.5	43.5	43.5	43.5	43.5	43.5	39.7	29.1	2.9	-	
Min. set pressure low press. bellows	p [psig] S/GL	29	-	14	20	16	26	22	15	17	20	-	-	
Maximum set pressure	p [psig] S/GL	232	-	232	232	232	232	232	232	232	232	232	-	
Max. set pressure with special spring	p [psig] S/GL	232	-	232	232	232	232	232	232	232	232	232	-	
Temperature acc. to DIN EN	min. [°F]	+14	-	+14										-
	max. [°F]	+572	-	+572										-
Temperature acc. to ASME	min. [°F]	-	-	-										-
	max. [°F]	-	-	-										-

Body material: 0.7043 (ductile Gr. 60-40-18)

DIN Flange		Inlet	-	-	PN 40						PN 16		PN 25
					PN 16						PN 16		PN 10
Minimum set pressure	p [psig] S/GL	-	-	1.5	1.5	1.5	1.5	1.5	1.5	1.5	1.5	1.5	1.5
Min. set pressure¹⁾ standard bellows	p [psig] S/GL	-	-	43.5	43.5	43.5	43.5	43.5	43.5	39.7	29.1	2.9	2.9
Min. set pressure low press. bellows	p [psig] S/GL	-	-	14	20	16	26	22	15	17	20	-	-
Maximum set pressure	p [psig] S/GL	-	-	580	580	580	580	580	464	580	232	232	290
Max. set pressure with special spring	p [psig] S/GL	-	-	580	580	580	580	580	580	580	232	232	363
Temperature acc. to DIN EN	min. [°F]	-	-	-						-76			
	max. [°F]	-	-	-						+662			
Temperature acc. to ASME	min. [°F]	-	-	-						+14			
	max. [°F]	-	-	-						+662			

¹⁾ Min. set pressure standard bellows = Max. set pressure low pressure bellows.

Pressure temperature ratings

US Units

DN _I	20	20	25	32	40	50	65	80	100	125	150	200
DN _O	32	40	40	50	65	80	100	125	150	200	250	300
Actual Orifice diameter d ₀ [inch]	0.71	0.71	0.91	1.14	1.46	1.81	2.36	2.91	3.62	3.86	4.92	6.5
Actual Orifice area A ₀ [inch ²]	0.394	0.394	0.644	1.024	1.667	2.576	4.383	6.666	1.304	11.691	19.021	33.142

Body material: 1.0619 (WCB)

DIN Flange	Inlet		PN 40										PN 25	
	Outlet		PN 16											
Minimum set pressure	p [psig]	S/GL	-	1.5	1.5	1.5	1.5	1.5	1.5	1.5	1.5	1.5	1.5	1.5
Min. set pressure¹⁾ standard bellows	p [psig]	S/GL	-	43.5	43.5	43.5	43.5	43.5	43.5	43.5	39.7	29.1	2.9	2.9
Min. set pressure low press. bellows	p [psig]	S/GL	-	29	14	20	16	26	22	15	17	20	-	-
Maximum set pressure	p [psig]	S/GL	-	580	580	580	580	580	580	464	580	406	247	290
Max. set pressure with special spring	p [psig]	S/GL	-	580	580	580	580	580	580	580	580	406	363	363
Temperature acc. to DIN EN	min. [°F]	-	-	-121										
	max. [°F]	-	-	+842										
Temperature acc. to ASME	min. [°F]	-	-	-20										
	max. [°F]	-	-	+800										

Body material: 1.4408 (CF8M)

DIN Flange	Inlet		PN 40										-	
	Outlet		PN 16											
Minimum set pressure	p [psig]	S/GL	-	-	1.5	1.5	1.5	1.5	1.5	1.5	1.5	1.5	1.5	-
Min. set pressure¹⁾ standard bellows	p [psig]	S/GL	-	-	43.5	43.5	43.5	43.5	43.5	43.5	39.7	29.1	2.9	-
Min. set pressure low press. bellows	p [psig]	S/GL	-	-	14	20	16	26	22	15	17	20	-	-
Maximum set pressure	p [psig]	S/GL	-	-	580	580	580	479	406	197	290	257	102	-
Max. set pressure with special spring	p [psig]	S/GL	-	-	580	580	580	537	406	363	377	348	145	-
Temperature acc. to DIN EN	min. [°F]	-	-	-454										
	max. [°F]	-	-	+752										
Temperature acc. to ASME	min. [°F]	-	-	-450										
	max. [°F]	-	-	+1000										

¹⁾ Min. set pressure standard bellows = Max. set pressure low pressure bellows.

Type 441, 442 DIN

LESER

Available Options

For further information refer to
"Accessories and Options", page 99/01

Type 441, 442 DIN

Heating jacket

H29, H30: Couplings G 3/8, G 3/4
H31, H32: Flanges DN 15, DN 25

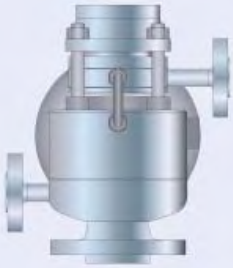

Drain hole

J18: G 1/4
J19: G 1/2

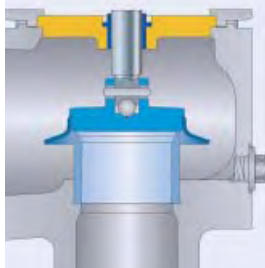

Open bonnet

See Art.-No.



O-ring-disc

J20: FFKM "C"
J21: CR "K"
J22: EPDM "D"
J23: FKM "L"

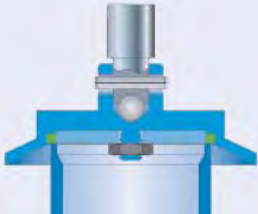

Disc with inserted sealing plate

J44: PTFE-FDA
J48: PCTFE
J49: SP

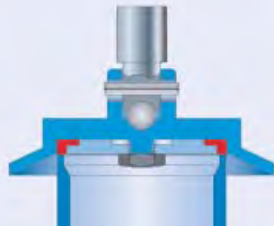

Stainless steel bellows

J68: Open bonnet
J78: Closed bonnet

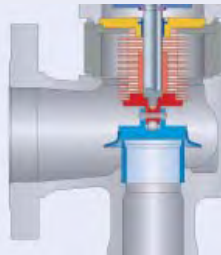

Conversion kit for stainless steel bellows

See Art.-No. page 06/15

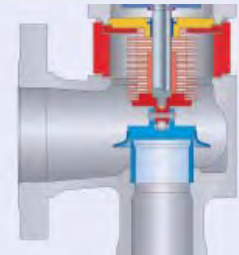

Screwed cap H2

H2

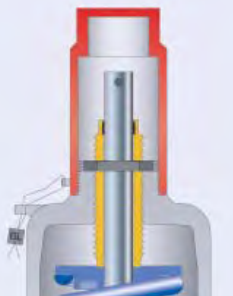

Plain lever H3

H3

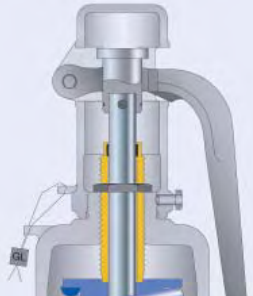

Packed lever H4

H4

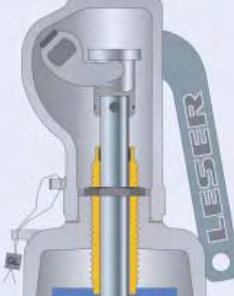

Test gag

J69: H4
J70: H2

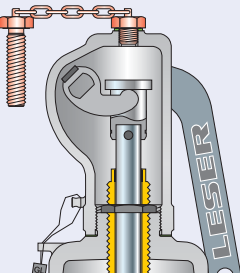

Lift indicator

J39: Adaptor H4
J93: Lift indicator

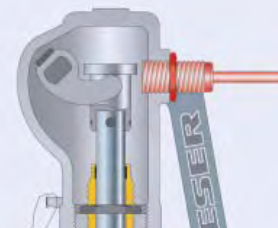

O-ring-damper H2

J65

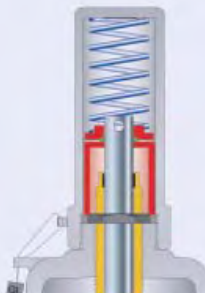

O-ring-damper H4

J66

