



Type

441 XXL
442 XXL

Flanged Safety Relief Valves
- spring loaded

US Units

Facts

LESER

The-Safety-Valve.com

Type 441, 442 XXL

LESER

Conventional design

Type 441, 442 XXL

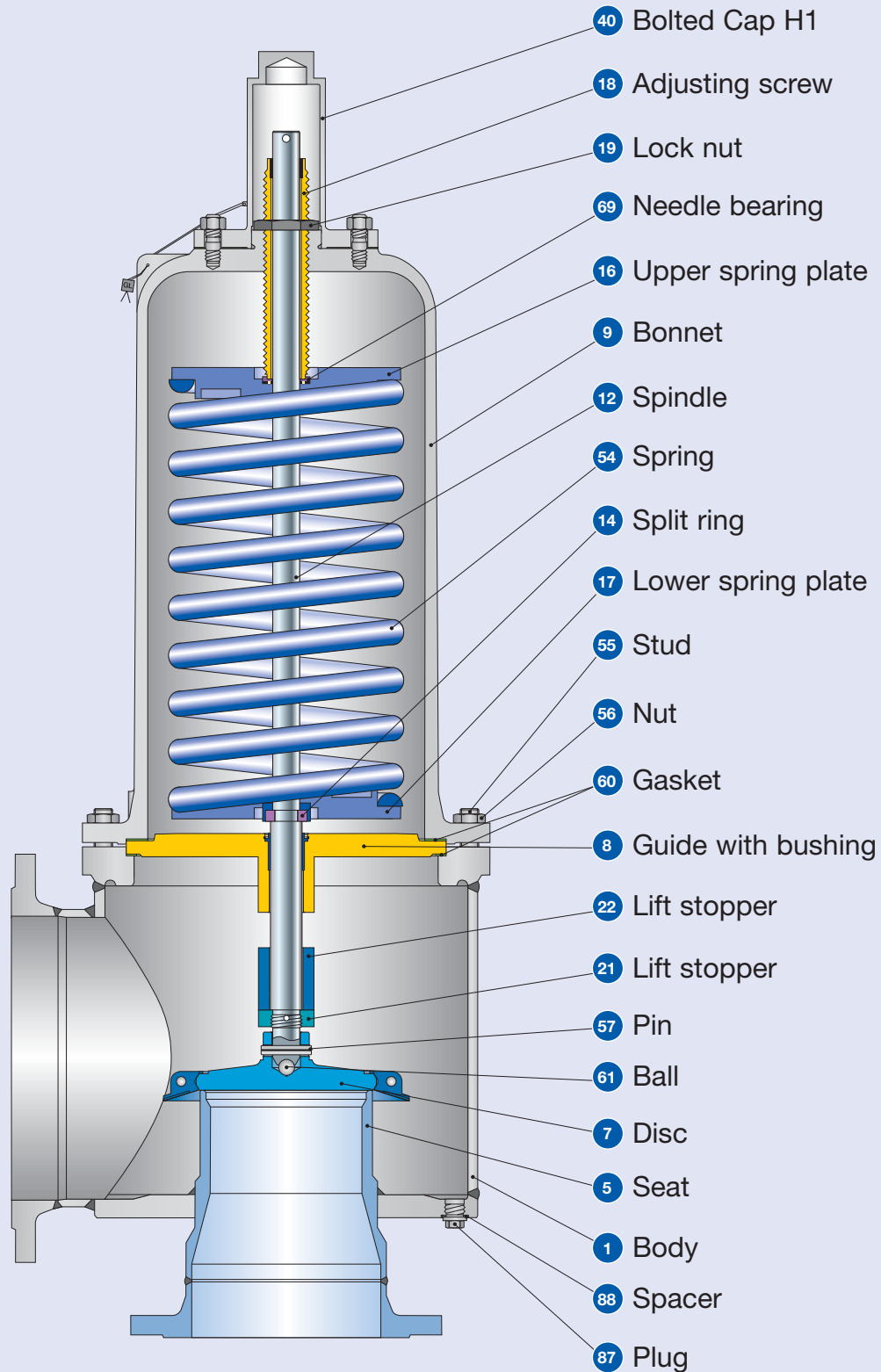

Conventional design

Materials			
Item	Component	Type 4412 XXL / 4422 XXL	Type 4414 XXL
1	Body	1.0460/1.0425	1.4571
		Carbon steel	316Ti
5	Seat	1.0305 stellite, 1.0460 stellite	1.4571
		Carbon steel, stellite	316Ti
7	Disc	1.4404	1.4404
		316L	316L
8	DN 200 – 250: Guide with bushing	0.7040	1.4404
		Ductile Gr. 60-40-18 / Chrome steel	316L
	DN 300 – 400: Guide	1.4404	1.4404
		316L	316L
9	Bonnet ¹⁾	1.0305 or 1.0254	1.4571 / 1.4404
		SA-106 or Steel	316Ti / 316L
12	Spindle	1.4021	1.4404
		420	316L
14	Split ring	1.4104	1.4404
		Chrome steel	316L
16 / 17	Spring plate	1.0570 or 1.4404	1.4404
		Steel or 316L	316L
18	Adjusting screw with bushing	1.4104 PTFE	1.4404 PTFE
		Chrome steel PTFE	316L PTFE
19	Lock nut	1.4404	1.4404
		316L	316L
21 / 22	Lift stopper	1.4404	1.4404
		316L	316L
40	Bolted cap H1	0.7040	1.4404
		Ductile Gr. 60-40-18	316L
54	Spring standard	1.1200, 1.8159, 1.7102	1.4310
		Carbon steel	Stainless steel
	Spring optional	1.4310	-
		Stainless steel	-
55	Stud	1.4401	1.4401
		B8M	B8M
56	Nut	1.4401	1.4401
		8M	8M
57	Pin	1.4310	1.4310
		Stainless steel	Stainless steel
60	Gasket	Graphite / 1.4401	Graphite / 1.4401
		Graphite / 316	Graphite / 316
61	Ball	1.3541	1.4401
		Hardened stainless steel	316
69	Needle bearing	1.4401	1.4401
		316L	316L
87 / 88	Plug / Spacer	1.4401 / 1.4571	1.4401 / 1.4571
		316 / 316Ti	316 / 316Ti

¹⁾ The welded construction might contain additional materials.

Please notice:

- Modifications reserved by LESER
- If several materials are specified LESER defines the material.
- LESER can upgrade materials without notice.
- Every part can be replaced by other material acc. to customer specification.

Type 441, 442 XXL

LESER

Balanced bellows design

Type 441, 442 XXL

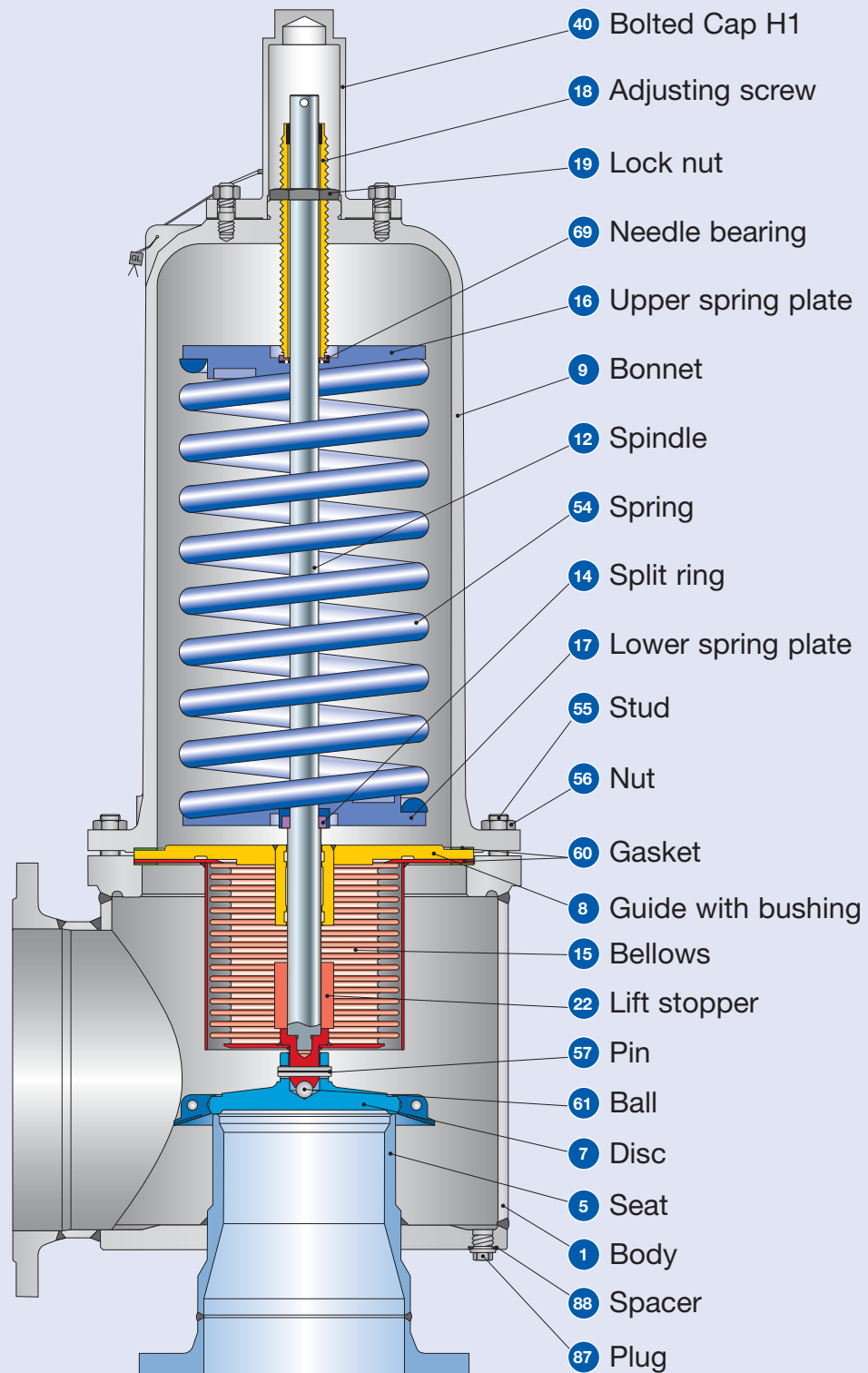

Balanced bellows design

Materials			
Item	Component	Type 4412 XXL / 4422 XXL	Type 4414 XXL
1	Body	1.0460/1.0425	1.4571
		Carbon steel	316Ti
5	Seat DN 200 – 250	1.0305 stellited	1.4571
		Carbon steel, stellited	316Ti
	DN 300 – 400	1.0460 stellited	1.4571
		Carbon steel, stellited	316Ti
7	Disc	1.4404	1.4404
		316L	316L
8	Guide	1.4571	1.4571
		316Ti	316Ti
9	Bonnet ¹⁾	1.0305 or 1.0254	1.4571 / 1.4404
		SA-106 or Steel	316Ti / 316L
12	Spindle	1.4404	1.4404
		316L	316L
14	Split ring	1.4104	1.4404
		Chrome steel	316L
15	Bellows	1.4571	1.4571
		316Ti	316Ti
16 / 17	Spring plate	1.0570 or 1.4404	1.4404
		Steel or 316L	316L
18	Adjusting screw with bushing	1.4104 PTFE	1.4404 PTFE
		Chrome steel PTFE	316L PTFE
19	Lock nut	1.4404	1.4404
		316L	316L
22	Lift stopper	1.4404	1.4404
		316L	316L
40	Bolted cap H1	0.7040	1.4404
		Ductile Gr. 60-40-18	316L
54	Spring standard	1.1200, 1.8159, 1.7102	1.4310
		Carbon steel	Stainless steel
	Spring optional	1.4310	-
55	Stud	1.4401	1.4401
		B8M	B8M
56	Nut	1.4401	1.4401
		8M	8M
57	Pin	1.4310	1.4310
		Stainless steel	Stainless steel
60	Gasket	Graphite / 1.4401	Graphite / 1.4401
		Graphite / 316	Graphite / 316
61	Ball	1.3541	1.4401
		Hardened stainless steel	316
69	Needle bearing	1.4401	1.4401
		316L	316L
87 / 88	Plug / Spacer	1.4401 / 1.4571	1.4401 / 1.4571
		316 / 316Ti	316 / 316Ti

¹⁾ The welded construction might contain additional materials.

Please notice:

- Modifications reserved by LESER
- If several materials are specified LESER defines the material.
- LESER can upgrade materials without notice.
- Every part can be replaced by other material acc. to customer specification.

How to order – Article numbers

Article numbers				200 x 300	250 x 350	300 x 400	400 x 500
		DN _{I+O}		200 x 300	250 x 350	300 x 400	400 x 500
		Valve size		8" x 12"	10" x 14"	12" x 16"	16" x 20"
		Actual Orifice diameter d ₀ [mm]		165	200	235	295
		Actual Orifice area A ₀ [mm ²]		21382	31416	43374	68349
Body material: 1.0460 / 1.0425 (Carbon steel)							
Bonnet closed	H1	Art.-No. 4412.		4752	4762	4772	4782
	H3	Art.-No. 4412.		–	–	–	–
	H6	Art.-No. 4412.		4754	4764	4774	4784
open	H6	Art.-No. 4422.		4755	4765	4775	4785
Body material: 1.4571 (316Ti)							
Bonnet closed	H1	Art.-No. 4414.		4792	4802	4902	4912
	H6	Art.-No. 4414.		4794	4804	4904	4914

Dimensions and weights

US Units					
	DN _{I+O}	200 x 300	250 x 350	300 x 400	400 x 500
	Valve size	8" x 12"	10" x 14"	12" x 16"	16" x 20"
	Actual Orifice diameter d ₀ [inch]	6.5	7.87	9.25	11.61
	Actual Orifice area A ₀ [inch ²]	33.143	48.695	67.229	105.942
Weight [lbs]		628	739	847	1297
	with bellows	637	750	860	1312
Center to face [inch]	Inlet a	12	13 ³ / ₈	13 (CL300: 13 ³ / ₄)	15 ³ / ₄ (CL300: 16 ⁵ / ₃₂)
	Outlet b	11 ¹³ / ₁₆	12 ¹³ / ₁₆	15 ¹ / ₂	18 ²⁵ / ₃₂
Height (H4) [inch]	Standard H max.	58	59 ³ / ₄	64 ⁵ / ₁₆	76 ⁷ / ₈
	Bellows H max.	58	59 ³ / ₄	64 ⁵ / ₁₆	76 ⁷ / ₈
Support brackets [inch] (drilled only on request)	A	18 ¹ / ₂	20 ¹ / ₄	25 ³ / ₁₆	31 ¹ / ₂
	B	5 ²⁹ / ₃₂	5 ²⁹ / ₃₂	7 ³ / ₃₂	8 ²¹ / ₃₂
	C	Ø ²⁹ / ₃₂	Ø ²³ / ₃₂	Ø ¹⁵ / ₁₆	Ø ³ / ₃₂
	D	12	13 ³ / ₈	13	15 ³ / ₄
	E	²⁵ / ₃₂	²⁵ / ₃₂	²⁵ / ₃₂	²⁵ / ₃₂

Body material: 1.0460 / 1.0425 (Carbon steel)

ANSI Flange Class¹⁾	Inlet	CL150 or CL300
	Outlet	CL150 or CL300

Body material: 1.4571 (316Ti)

ANSI Flange Class¹⁾	Inlet	CL150 or CL300
	Outlet	CL150 or CL300

¹⁾ Standard flange rating. For other flange drillings and facings please refer to page 03/14.

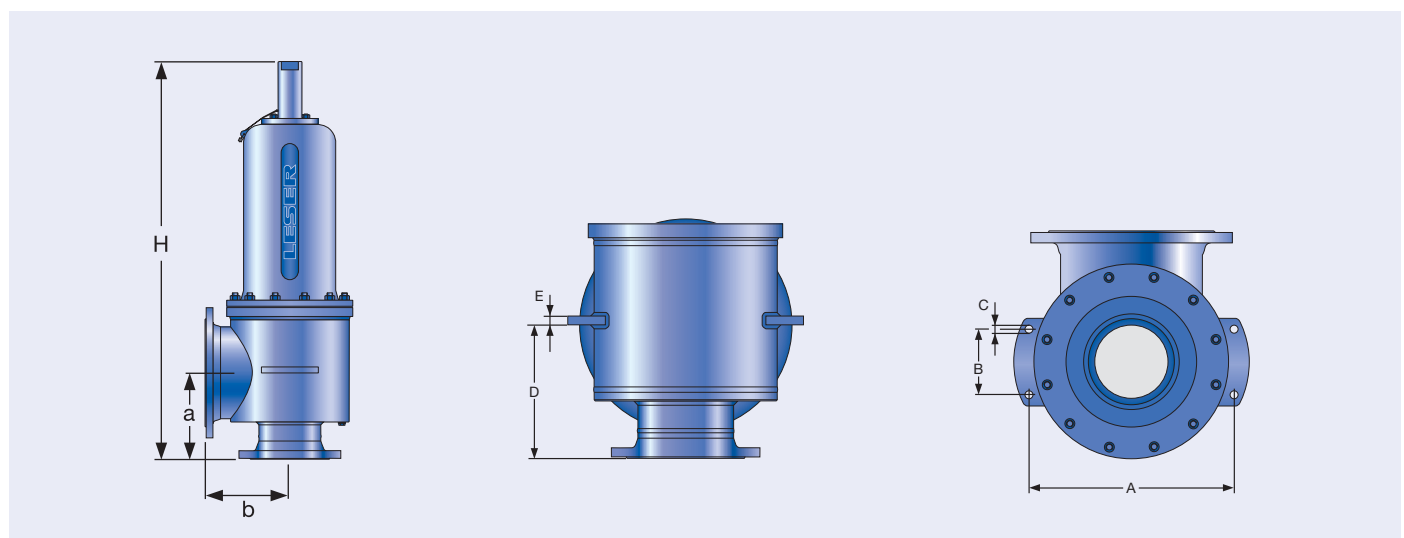

Conventional and balanced bellows design

Support brackets

Pressure temperature ratings

US Units						
	DN _{I+O}	200 x 300	250 x 350	300 x 400	400 x 500	
	Valve size	8" x 12"	10" x 14"	12" x 16"	16" x 20"	
	Actual Orifice diameter d ₀ [inch]	6.5	7.87	9.25	11.61	
	Actual Orifice area A ₀ [inch ²]	33.143	48.695	67.229	105.942	
Body material: 1.0460 / 1.0425 (Carbon steel)						
ANSI Flange Class ¹⁾	Inlet		CL150 or CL300			
	Outlet		CL150			
Minimum set pressure	p [psig]	S/G/L	2.9	2.9	2.9	2.9
Min. set pressure²⁾ standard bellows	p [psig]	S/G/L	2.9	2.9	2.9	2.9
Min. set pressure low press. bellows	p [psig]	S/G/L	-	-	-	-
Maximum set pressure	p [psig]	S/G/L	290	194	134	18
Max. set pressure with special spring	p [psig]	S/G/L	363	232	232	116
Temperature acc. to DIN EN	min. [°F]		-121			
	max. [°F]		+788			
Temperature acc. to ASME	min. [°F]		-300			
	max. [°F]		+800			
Body material: 1.4571 (316Ti)						
ANSI Flange Class ¹⁾	Inlet		CL150 or CL300			
	Outlet		CL150			
Minimum set pressure	p [psig]	S/G/L	2.9	2.9	2.9	2.9
Min. set pressure²⁾ standard bellows	p [psig]	S/G/L	2.9	2.9	2.9	2.9
Min. set pressure low press. bellows	p [psig]	S/G/L	-	-	-	-
Maximum set pressure	p [psig]	S/G/L	21	0	0	0
Max. set pressure with special spring	p [psig]	S/G/L	145	87	52	33
Temperature acc. to DIN EN	min. [°F]		-321			
	max. [°F]		+1022			
Temperature acc. to ASME	min. [°F]		-300			
	max. [°F]		+800			

¹⁾ For flange rating class 150 the pressure temperature ratings according to ASME ANSI B 16.34 apply.

²⁾ Min. set pressure standard bellows = Max. set pressure low pressure bellows.

Available Options

For further information refer to
"Accessories and Options", page 99/01

Type 441, 442 XXL

