

Type 444 ANSI

Flanged Safety Relief Valves
- spring loaded

Metric + US Units



Facts

LESER

The-Safety-Valve.com

Conventional design

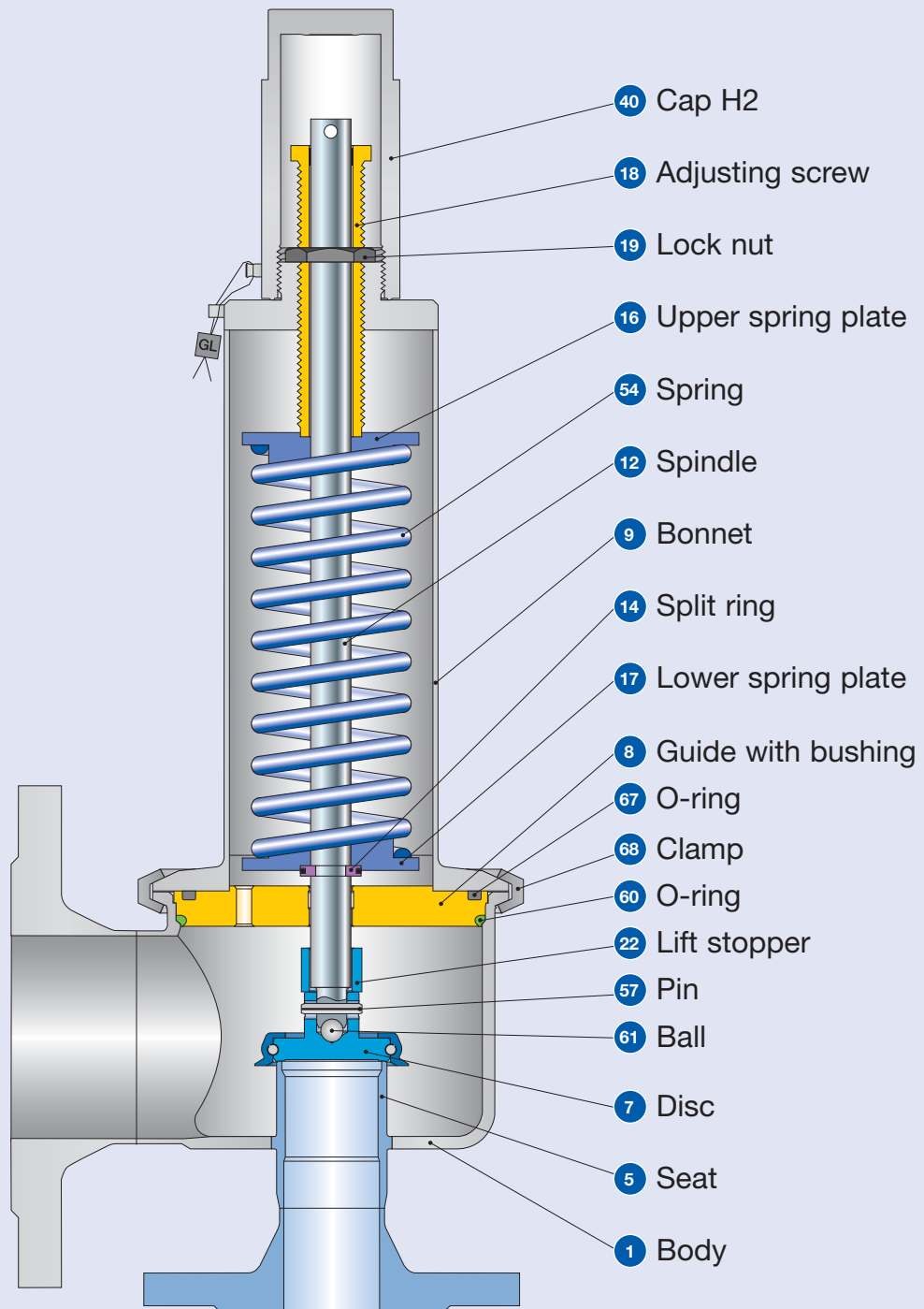

Conventional design

Materials		
Item	Component	Type 4444 ANSI
1	Body	1.4404
		SA 479 316L
5	Seat	1.4404
		316L
7	Disc	1.4404
		316L
8	Guide	1.4404
		316L
	with bushing	PTFE +15% glass PTFE +15% glass
9	Bonnet	1.4404
		SA 479 316L
12	Spindle	1.4404
		316L
14	Split ring	1.4404
		316L
16 / 17	Spring plate	1.4404
		316L
18	Adjusting screw with bushing	1.4404, PTFE + 15% glass
		316L, PTFE + 15% glass
19	Lock nut	1.4404
		316L
22	Lift stopper	1.4404
		316L
40	Cap H2	1.4404
		316L
54	Spring	1.4310
		Stainless steel
57	Pin	1.4310
		302
60	O-ring	EPDM-FDA
		EPDM-FDA
61	Ball	1.4401
		316
67	O-ring	EPDM-FDA
		EPDM-FDA
68	Clamp	1.4401
		316

Please notice:

- Modifications reserved by LESER.
- LESER can upgrade materials without notice.
- Every part can be replaced by other material acc. to customer specification.

Dimensions and weights

Metric Units

Valve size	1" x 2"	1 1/2" x 3"	2" x 3"	2 1/2" x 4"	3" x 4"	3" x 4"
Actual Orifice diameter d ₀ [mm]	23	37	46	60	74	74
Actual Orifice area A ₀ [mm ²]	416	1075	1662	2827	4301	4301
Set pressure range S/G/L [bar _g]	see page 05/08				0.1 – 6.8	6.81 – 16
Weight [kg]	7	13	14	23	24	24
Center to face [mm]	Inlet a	85	110	110	125	125
	Outlet b	90	128	128	160	160
Height (H4) [mm] Standard H max.	308	519	519	631	631	631

Body material: 1.4404 (316L)

ANSI Flange Class	Inlet	CL150
	Outlet	CL150

US Units

DN _i	1" x 2"	1 1/2" x 3"	2" x 3"	2 1/2" x 4"	3" x 4"	3" x 4"
Actual Orifice diameter d ₀ [inch]	0.91	1.46	1.81	2.36	2.91	2.91
Actual Orifice area A ₀ [inch ²]	0.644	1.667	2.576	4.383	6.666	6.666
Set pressure range S/G/L [psig]	see page 05/08				1.5 – 98.6	98.61 – 232
Weight [lbs]	16	29	31	51	53	53
Center to face [inch]	Inlet a	3 3/8	4 5/16	4 5/16	4 15/16	4 15/16
	Outlet b	3 1/2	5 1/16	5 1/16	6 5/16	6 5/16
Height (H4) [inch] Standard H max.	12 1/8	20 7/16	20 7/16	20 13/16	20 13/16	20 13/16

Body material: 1.4404 (316L)

ANSI Flange Class	Inlet	CL150
	Outlet	CL150

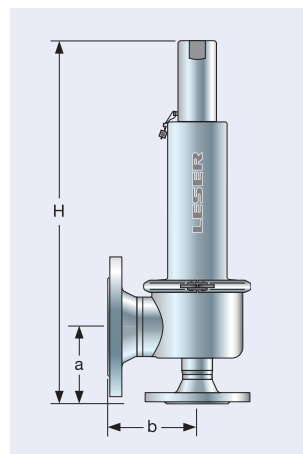

Conventional design

Pressure temperature ratings

Metric Units

Valve size	1" x 2"	1½" x 2"	2" x 3"	2½" x 4"	3" x 4"	3" x 4"	
Actual Orifice diameter d ₀ [mm]	23	37	46	60	74	74	
Actual Orifice area A ₀ [mm ²]	416	1075	1662	2827	4301	4301	
Body material: 1.4404 (316L)							
ANSI Flange Class¹⁾	Inlet	CL150					
	Outlet	CL150					
Minimum set pressure	p [bar _g] S/G/L	0.1	0.1	0.1	0.1	0.1	6.81
Maximum set pressure	p [bar _g] S/G/L	16	16	16	16	6.8	16
Temperature	min. [°C]	-45					
acc. to DIN EN	max. [°C]	+200					
Temperature	min. [°C]	-45					
acc. to ASME	max. [°C]	+200					

US Units

Valve size	1" x 2"	1½" x 2"	2" x 3"	2½" x 4"	3" x 4"	3" x 4"	
Actual Orifice diameter d ₀ [inch]	0.91	1.46	1.81	2.36	2.91	2.91	
Actual Orifice area A ₀ [inch ²]	0.644	1.667	2.576	4.383	6.666	6.666	
Body material: 1.4404 (316L)							
ANSI Flange Class¹⁾	Inlet	CL150					
	Outlet	CL150					
Minimum set pressure	p [psig] S/G/L	1.5	1.5	1.5	1.5	1.5	98.61
Maximum set pressure	p [psig] S/G/L	232	232	232	232	98.6	232
Temperature	min. [°F]	-49					
acc. to DIN EN	max. [°F]	+392					
Temperature	min. [°F]	-49					
acc. to ASME	max. [°F]	+392					

¹⁾ For flange rating class 150 the pressure temperature ratings according to ASME ANSI B 16.34 apply.

Available Options

For further information refer to "Accessoires and Options", page 99/01

