

Steam Media

Safety Shut-off Flap Valve, Compensator

Shut-off Flap Valve Type KSK



Application

Safety shut-off flap valve in coal dust pipework.

Nominal diameter: 150 to 800 mm

Operating pressure: Up to 10 bar

Operating temperature: Up to 200 °C

Technical Data

Valve body: Welded steel construction with inspection hole for service and maintenance during built-in

Seals: Metal-to-metal or metal-to-elastomers

Bearing: Maintenance-free plain bearings

Actuator:

- Manuel
- Pneumatic
- Elektric

Connection to pipework by flanges or welding to suit customers' specifications.

Compensator Type KG

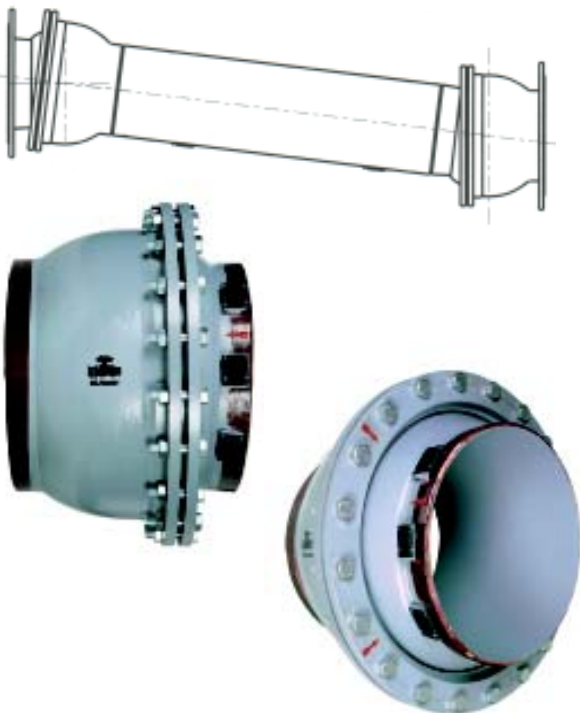

Application

Compensation of thermal Boiler Expansion to the axis of the connected coal dust lines

Nominal diameter: 150 to 800 mm

Operating pressure: Up to 10 bar

Operating temperature: Up to 200 °C

Technical Data

Body: Welded steel construction

Seal: Special silicone-rubber

Pipeline connection with flanged or welded ends, according to customers' request.