

MX13, 25, 30 and 40 Disc Brake Caliper

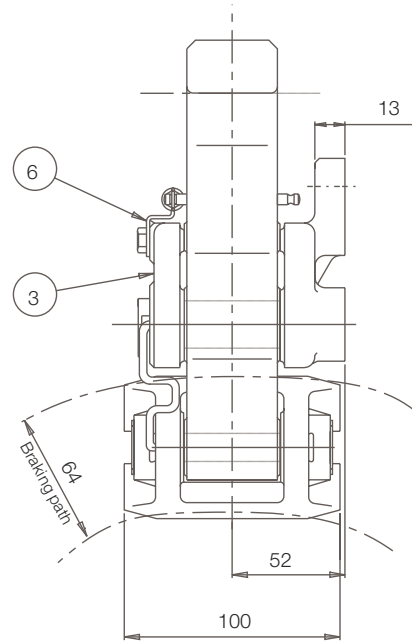

Bolt M12 Grade 8.8
Tightening Torque 87Nm
Not Supplied with Caliper

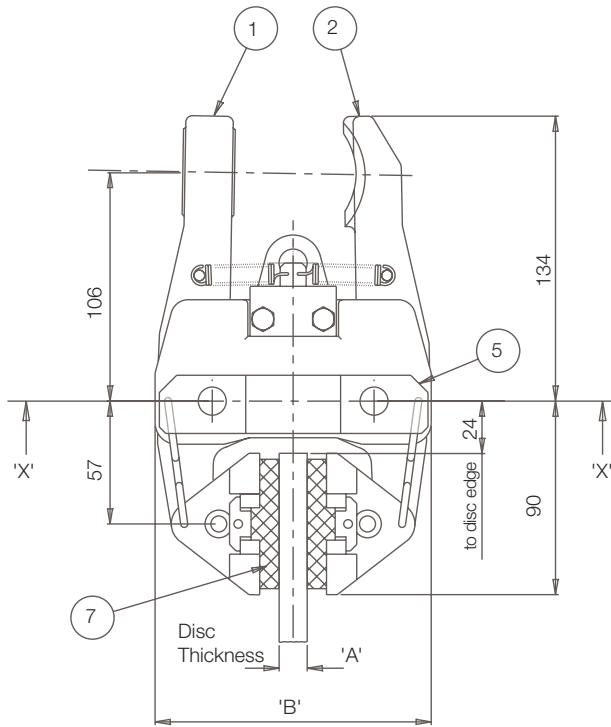
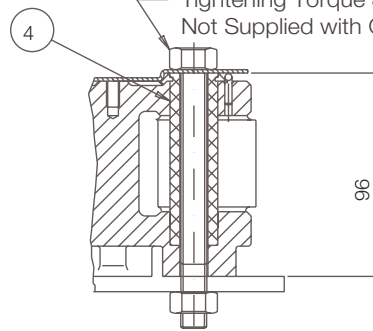
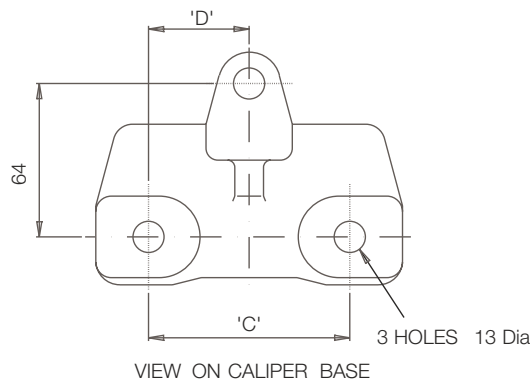

PART SECTION 'X-X'

Caliper	Part No.	Dimensions in mm			
		A	B	C	D
MX13	6780685	12.7	130	75	37.5
MX25	6780710	25.4	134	84	42
MX30	6780711	30	142	75	37.5
MX40	6780712	40	150	84	42

Weight of caliper -7.0kg
Total pad area -104cm² (2pads)
Pad dimensions new -60 x 90 x 13mm thick
Pad material -Asbestos-free high friction material

Allowable pad wear -8mm per pad
The standard MX series brake caliper, is supplied as a right-hand assembly. (as shown above) Left-hand assembly can be supplied on request, or can easily be changed on site.

MX13, 25, 30 and 40 Disc Brake Caliper

General Description

The Twiflex MX13, MX25, MX30 & MX40 disc brake calipers are used with brake discs of 12.7, 25.4, 30 & 40mm thickness respectively. They may be used with any of the series of actuators listed below.

Normally one or two units will be used per disc but the number may be increased, depending on disc size

Thruster	Description	Data Sheet	Maximum Braking Force
A	Pneumatically applied spring released	2501	6.9
B	Pneumatically applied spring released	2502	11
D	Pneumatically applied spring released	2503	3.6
E	Pneumatically applied spring released	2504	0.74
G	Pneumatically applied spring released	2505	1.9
H	Mechanically applied hand operated	2506	8.3
K	Spring applied pneumatically released	2507	2.15, 4.3 and 6.4
L	Spring applied pneumatically released	2508	2.15, 4.3 and 6.4
XS	Spring applied pneumatically released	2509	6.8, 11.2 and 14.3
XSH	Spring applied hydraulically released	2510	6.8, 11.2 and 14.3
W	Mechanically applied hand operated	2511	2.68
EMX	Spring applied electrically released	2512	6.1

The brake units can be positioned at any angle around the periphery of the disc, but ideally they should be mounted horizontally (in 3 or 9 o'clock positions) in relation to the disc.

If a caliper is mounted at an angle of more than about 10 deg. from the horizontal it should be fitted with an inclined mounting kit or equalising link. This applies also to calipers used on vertical shaft installations.

Discs:

A range of standard discs of 12.7mm and 25.4mm thickness are available from Twiflex see Data Sheet DS5002. Minimum disc diameter for the MX caliper is 300mm

Controllers:

Standard Twiflex Controllers are available for single or multi-caliper installations for use with electric, pneumatic and hydraulic signalling systems.

Pad replacement in air applied calipers:

To replace the pads, secure the installation to ensure safety.

Straighten tabs at each end of the brake pads, and remove worn pads. Clean disc and the pad recesses in the shoes with a suitable cleaning agent such as white spirit. Fit new pads, and bend tabs through 90 deg. so as to hold pads in position, the pad should be free to move sideways.

Pad replacement in spring applied calipers:

To replace the pads, secure the installation to ensure safety.

Slacken the two locknuts holding the thruster, and screw back the push rod to create space between pad and disc. Straighten tabs at each end of the brake pads, and remove worn pads. Clean disc and the pad recesses in the shoes with a suitable cleaning agent such as white spirit. Fit new pads, and bend tabs through 90 deg. so as to hold pads in position, the pad should be free to move sideways.

Refit the thruster as described in the relevant data sheet

Available Spares					
Caliper		MX13	MX25	MX30	MX40
Item	Component	Part No.	Part No.	Part No.	Part No.
1	Arm Assembly -Thruster	6630145	6630145	6630149	6630149
2	Arm Assembly -Slotted	6630146	6630145	6630150	6630150
3	Caliper Base	8030025	8030026	8030025	8030026
4	Pivot Pin	7952383	7952383	7952383	7952383
5	Retaining Plate	7951480	7951480	7951480	7951480
6	Spring Anchor Plate	7951501	7951501	7951501	7951501
7	Pad Assembly (2 Pads)	7080118-Z-SS2	7080118-Z-SS2	7080118-Z-SS2	7080118-Z-SS2
	Spring Kit	7902813	7902813	7902813	7902813
	Inclined Mounting Kit	7901512	7901512	7901512	7901512

For bedding-in and conditioning procedures see publication M1060
Health and Safety data sheet reference to DS 0500