

IVR-4XXX

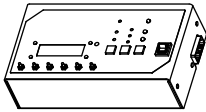

Components

① CN-100



② Power cable



③ Cable assy.

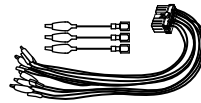

④ This Manual

Features

- Line Voltage Requirements : 100~240VAC / 50Hz-60Hz
- This checker can inspect New-Era regulators (IVR for 12V & 24V).
- This checker has the function to protect over current.

The meaning for Display

- ① OVER CURRENT : To figure out current surge
- ② SHORT CIRCUIT : In case of short circuit during inspecting on STEP1 or STEP 2, short circuit is happened inside of IVR Circuit
- ③ SHORT CIRCUIT ST : In case of short circuit before inspecting on STEP 1 or STEP 2, short circuit is happened by wrong wiring

※When new item regulators will be added on current regulator list, you could get new data by downloading from HP as below.

"<http://www.newera.co.jp/product/ivrchecker/cn100.html>"

※The contents in our instruction manual would be changed without prior announcement.

Connection / Setting

1. Connect **Cable assy.** and **Power cable** to CN-100
2. Turn **Power switch** on
3. Connect **IVR** to **CN-100**
4. Select **>LA** or **LB**
 - >**S&Dummy** or **C off** or **C on**
 - >**Choke Drive** or **No Choke Drive**
 - >**T off** or **T on**
 - >**R1** or **Off** or **Step1 Skip**
 - >**R2** or **Off** or **B-T Short**

Operation

- ① Select **12V** or **24V**
- ② Press **Step** :STEP1
Step :STEP2
- ③ End of check , Press **Reset**
- ④ Connect next IVR
- ⑤ Same model :return ②
Other model :return 3.

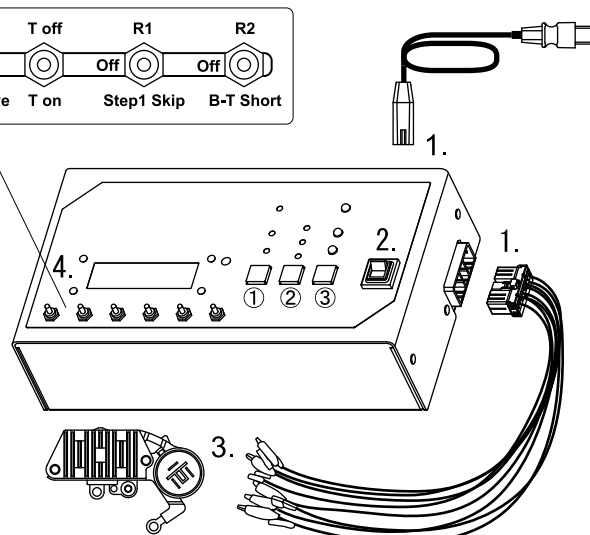
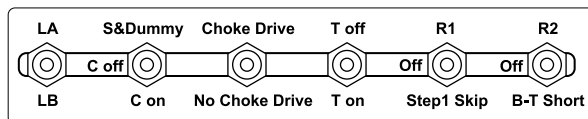

IVR-401

LA	S&Dummy	Choke Drive	T off	R1	R2
	C off			Off	Off
LB	C on	No Choke Drive	T on	Step1 Skip	B-T Short

STEP1 : Charge Lamp
 STEP2 : Choke Drive
 Regulated voltage **14.0V ~ 15.1V**

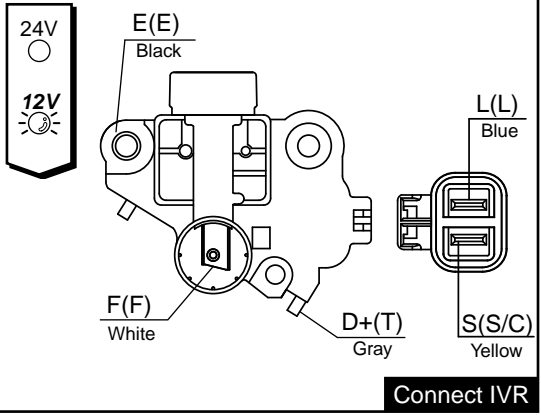

Connect IVR

IVR-402

LA	S&Dummy	Choke Drive	T off	R1	R2
	C off			Off	Off
LB	C on	No Choke Drive	T on	Step1 Skip	B-T Short

STEP1 : Charge Lamp
 STEP2 : Choke Drive
 Regulated voltage **14.0V ~ 15.1V**

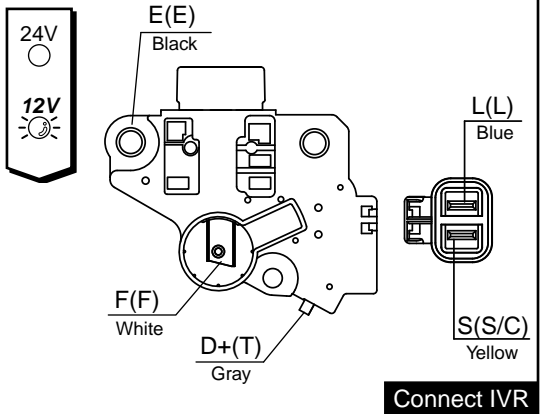

Connect IVR

IVR-403

LA	S&Dummy	Choke Drive	T off	R1	R2
	C off			Off	Off
LB	C on	No Choke Drive	T on	Step1 Skip	B-T Short

STEP1 : Charge Lamp
 STEP2 : Choke Drive
 Regulated voltage **14.0V ~ 15.1V**

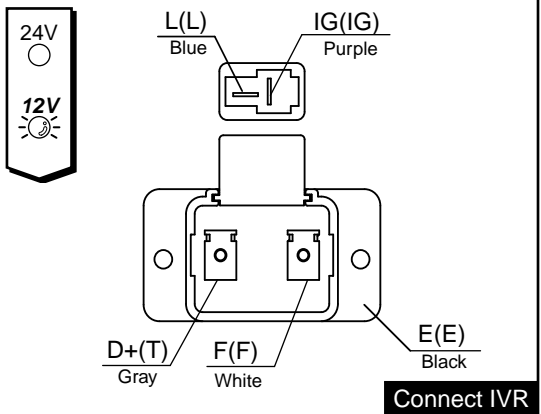

Connect IVR

IVR-404

LA	S&Dummy	Choke Drive	T off	R1	R2
	C off			Off	Off
LB	C on	No Choke Drive	T on	Step1 Skip	B-T Short

STEP1 : Charge Lamp
 STEP2 : Choke Drive
 Regulated voltage **14.0V ~ 15.1V**

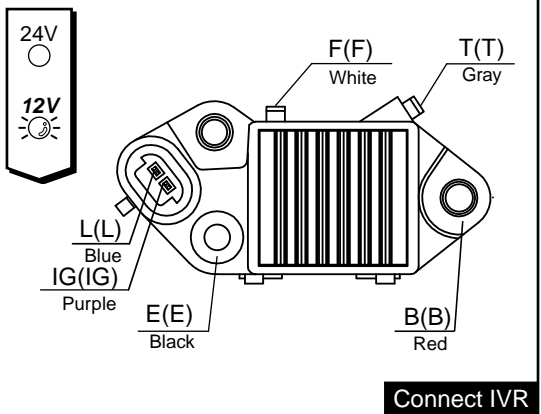

Connect IVR

LA	S&Dummy	Choke Drive	T off	R1	R2
	C off			Off	Off
LB	C on	No Choke Drive	T on	Step1 Skip	B-T Short

STEP1 : Charge Lamp

STEP2 : Choke Drive

Regulated voltage **14.0V ~ 15.1V**

24V

12V

Connect IVR

IVR-405

LA	S&Dummy	Choke Drive	T off	R1	R2
	C off			Off	Off
LB	C on	No Choke Drive	T on	Step1 Skip	B-T Short

STEP1 : Charge Lamp

STEP2 : Choke Drive

Regulated voltage **14.0V ~ 15.1V**

24V

12V

Connect IVR

IVR-406

LA	S&Dummy	Choke Drive	T off	R1	R2
	C off			Off	Off
LB	C on	No Choke Drive	T on	Step1 Skip	B-T Short

STEP1 : Charge Lamp

STEP2 : Choke Drive

Regulated voltage **14.0V ~ 15.1V**

24V

12V

Connect IVR

IVR-407

LA	S&Dummy	Choke Drive	T off	R1	R2
	C off			Off	Off
LB	C on	No Choke Drive	T on	Step1 Skip	B-T Short

STEP1 : Charge Lamp

STEP2 : Choke Drive

Regulated voltage **14.0V ~ 15.1V**

24V

12V

Connect IVR

IVR-408

IVR-409

LA	S&Dummy	Choke Drive	T off	R1	R2
	C off			Off	Off
LB	C on	No Choke Drive	T on	Step1 Skip	B-T Short

STEP1 : Charge Lamp
 STEP2 : Choke Drive
 Regulated voltage **14.0V~15.1V**■

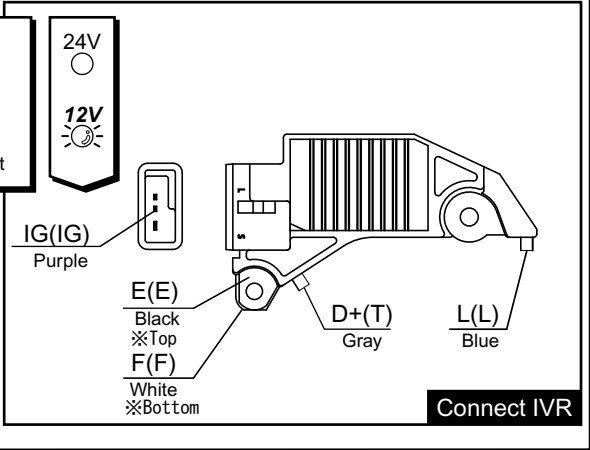

Connect IVR

IVR-410

LA	S&Dummy	Choke Drive	T off	R1	R2
	C off			Off	Off
LB	C on	No Choke Drive	T on	Step1 Skip	B-T Short

STEP1 : Charge Lamp
 STEP2 : Choke Drive
 Regulated voltage **14.0V~15.1V**■

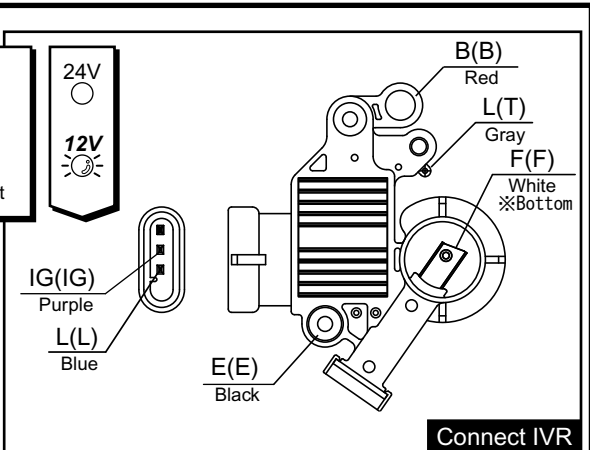

Connect IVR

IVR-411

LA	S&Dummy	Choke Drive	T off	R1	R2
	C off			Off	Off
LB	C on	No Choke Drive	T on	Step1 Skip	B-T Short

STEP1 : Charge Lamp
 STEP2 : Choke Drive
 Regulated voltage **14.0V~15.1V**■

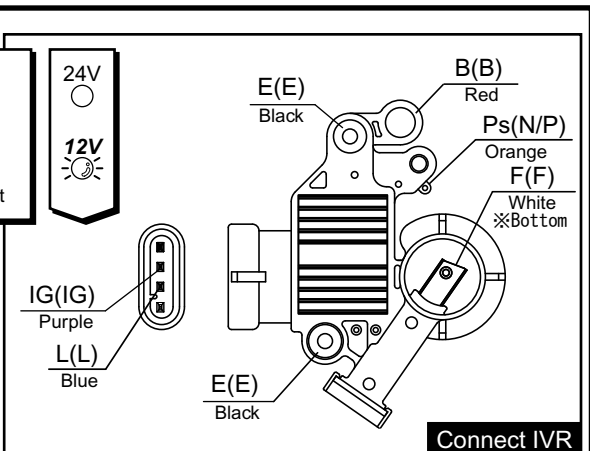

Connect IVR

IVR-412

LA	S&Dummy	Choke Drive	T off	R1	R2
	C off			Off	Off
LB	C on	No Choke Drive	T on	Step1 Skip	B-T Short

STEP1 : Charge Lamp
 STEP2 : Choke Drive ○
 Regulated voltage **14.0V~15.1V**■

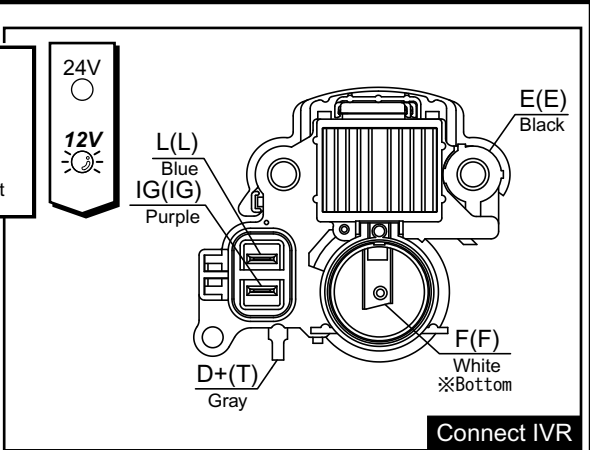

Connect IVR

This checker, CN-100, can not inspect IVR-413 due to its unique circuit design.

24V
○
12V
○

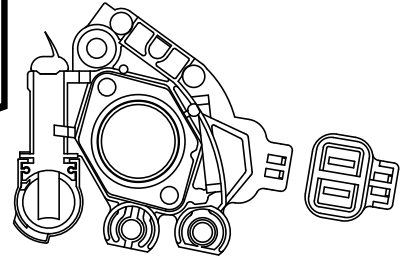

Connect IVR

LA	S&Dummy	Choke Drive	T off	R1	R2
	C off			Off	Off
LB	C on	No Choke Drive	T on	Step1 Skip	B-T Short

24V
○
12V
☀

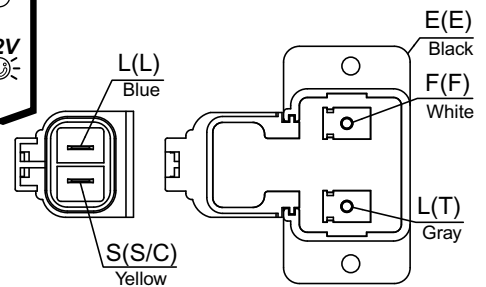

Connect IVR

STEP1 : Charge Lamp ☀....
STEP2 : Choke Drive ○
Regulated voltage **14.0V~15.1V**■

LA	S&Dummy	Choke Drive	T off	R1	R2
	C off			Off	Off
LB	C on	No Choke Drive	T on	Step1 Skip	B-T Short

24V
○
12V
○

STEP1 : Charge Lamp ○
STEP2 : Choke Drive ○
Regulated voltage....■

Connect IVR

LA	S&Dummy	Choke Drive	T off	R1	R2
	C off			Off	Off
LB	C on	No Choke Drive	T on	Step1 Skip	B-T Short

24V
○
12V
○

STEP1 : Charge Lamp ○
STEP2 : Choke Drive ○
Regulated voltage....■

Connect IVR