

RV Series Vibrating Motors

Powerful vibration for flow-resistant materials

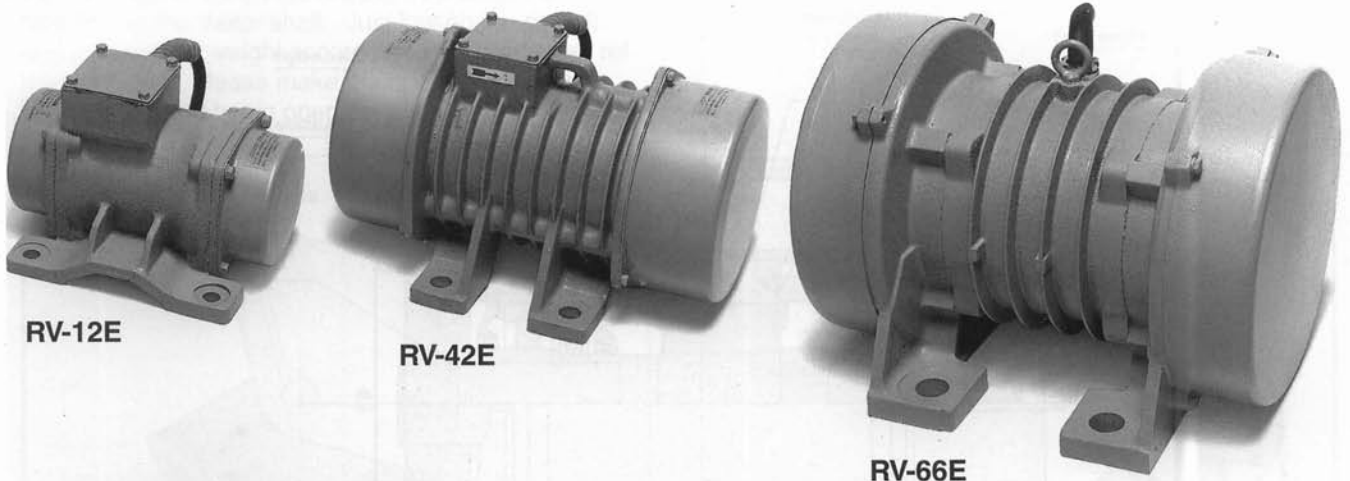

The RV series vibrating motors feature an unbalanced weight attached to the rotor shaft that generates an excitation force to produce powerful vibration. Designed for large-capacity hoppers, bins and chutes, these motors easily shift flow-resistant or sticky materials. Even materials that have proved hard to handle with other vibration equipment can be conveyed smoothly, with no clogging and arching problems. Ideal drive units for all types of vibratory equipment.

Features

1. Strong excitation force

The use of an unbalanced weight directly connected to the rotor shaft gives a very powerful excitation force per single revolution. Ideal for use with large-capacity hoppers, and materials that resist flow.

2. Compact and easy to install

The body is notably compact for a high output motor, and takes up very little space. It features straightforward 4-bolt fixture.

3. Adjustable excitation force

Excitation force is adjusted simply by modifying the angle of the unbalanced weight on the rotor shaft. Desired force can be set by loosening the bolt and re-aligning the adjustable weight on the graduated reference plane.

4. Low noise

Despite powerful performance, little noise is generated to disrupt the working environment.

5. Wide product line-up

The RV series includes 2, 4, 6, and 8 pole motors, each with a series of models according to excitation force. This line-up assures the ideal match to suit the material and task. Additionally a reinforced pressure-tight model is available for safe use in risky locations.

6. Ideal drive units for all types of vibratory equipment

Broad range of applications as drive units for all types of vibrators, feeders, screens and conveyors.

Structural Diagram for B Type (RV-758B₁₂)

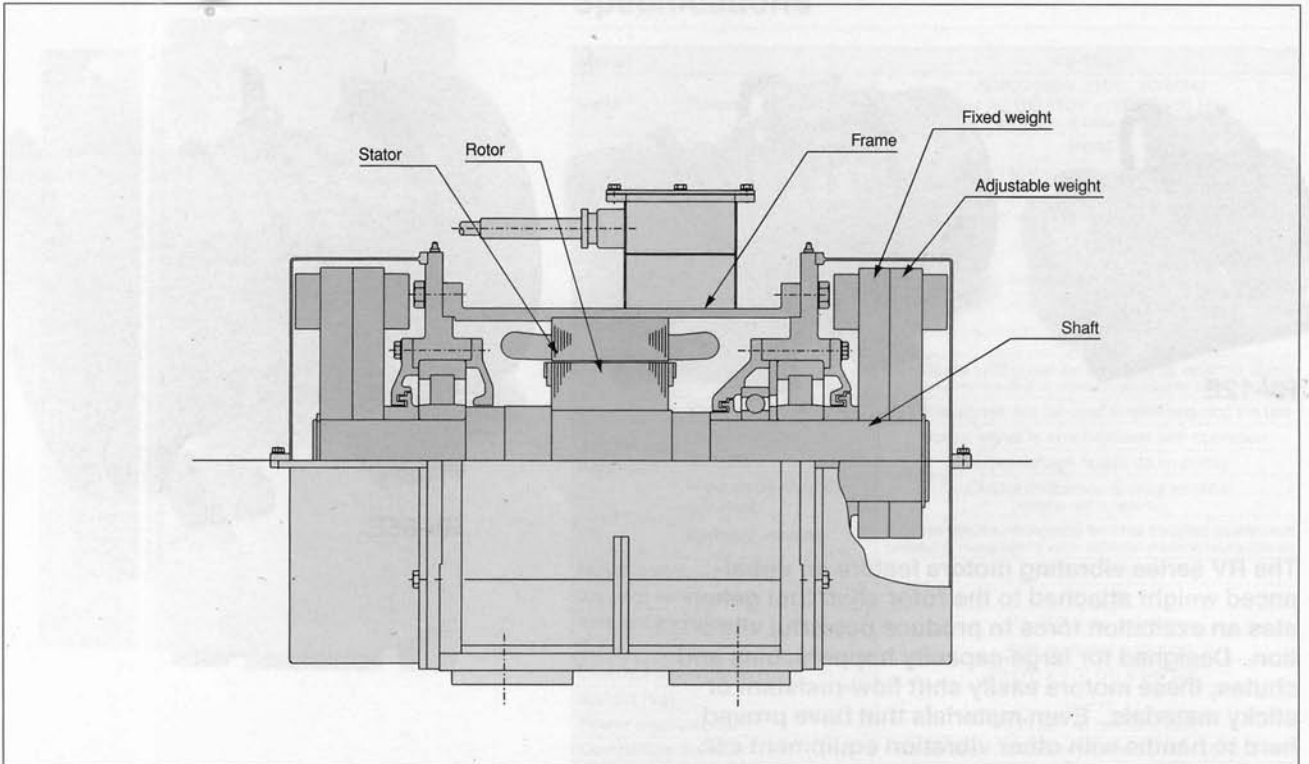

Structural Diagram for E Type (RV-72E)

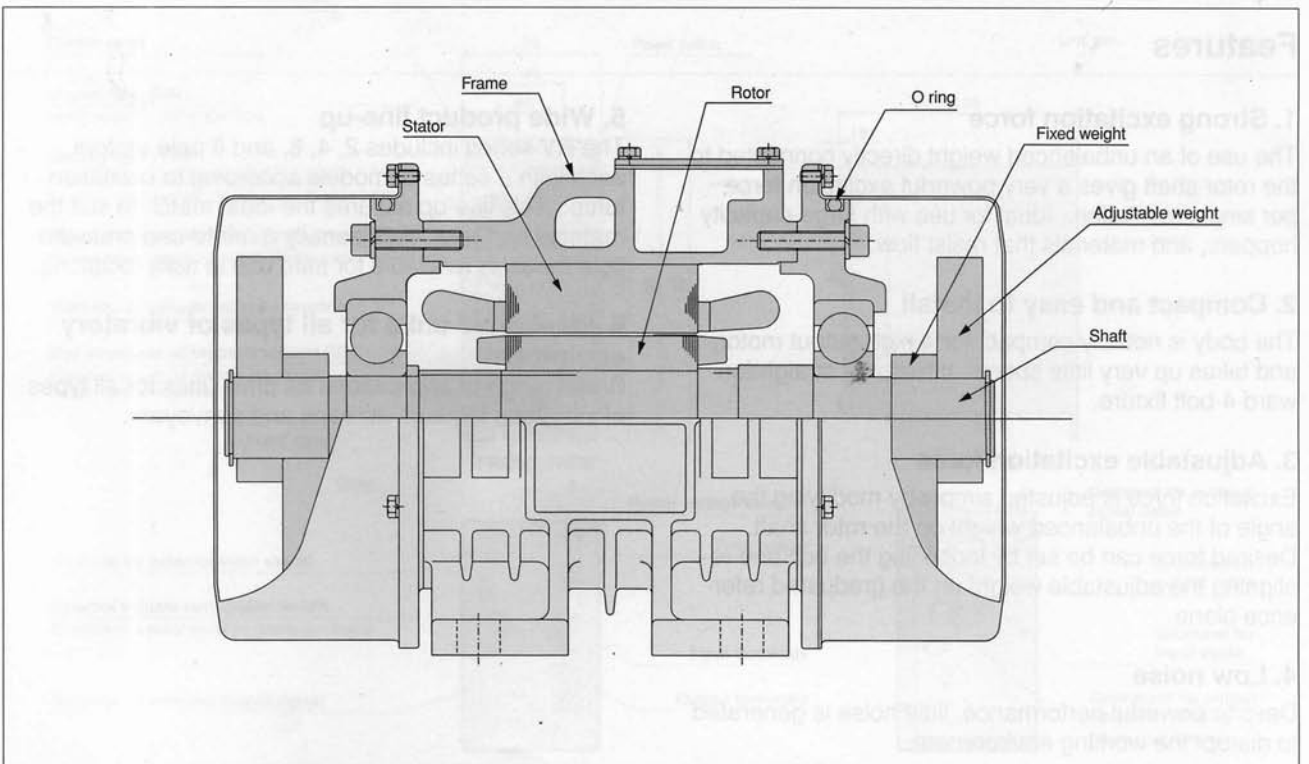

Adjusting Excitation Force

The excitation force can be adjusted simply by changing the angle at which the unbalanced weight is attached to the motor shaft. Just loosen the tie bolt and position the weight according to the graduated reference plane. Please make the appropriate adjustment before you begin operations.

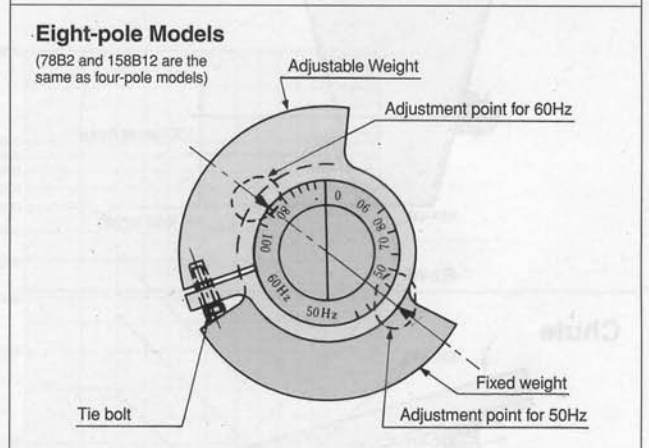
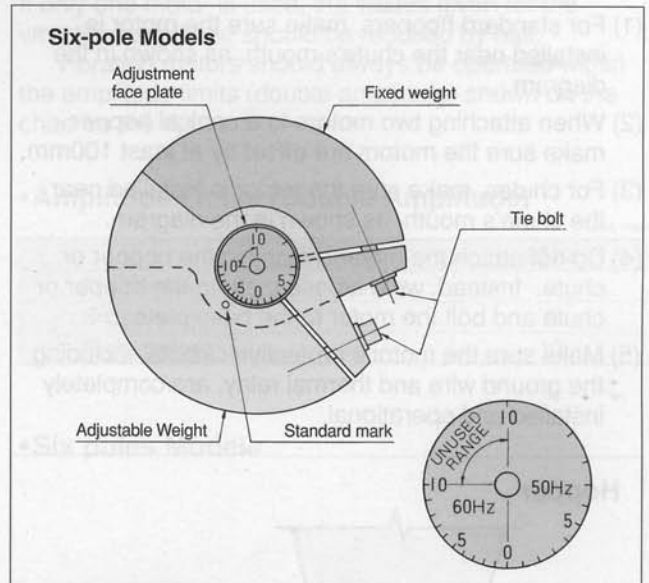
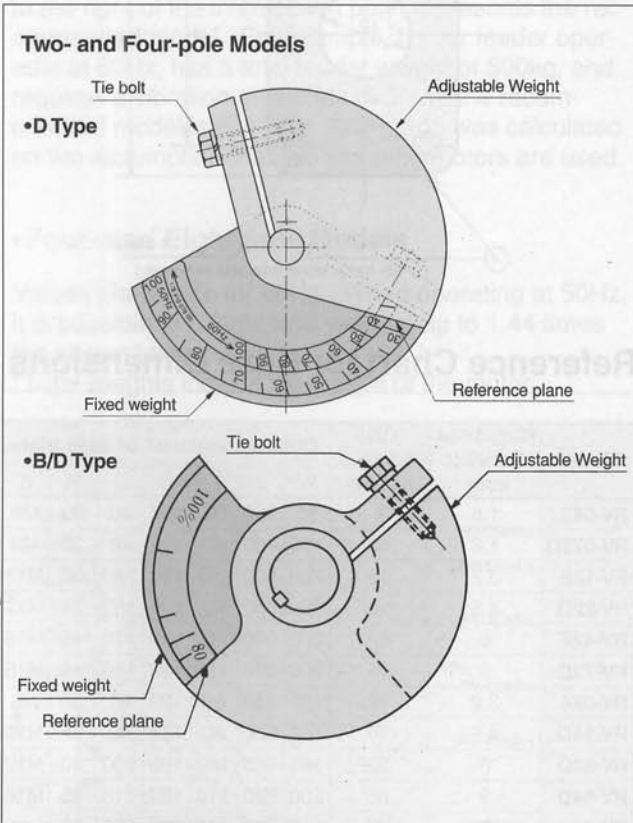

RV-64

Model Indication

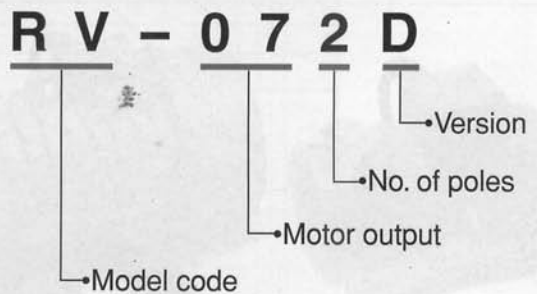

Examples of Motor Installation

- (1) For standard hoppers, make sure the motor is installed near the chute's mouth, as shown in the diagram.
- (2) When attaching two motors to a conical hopper, make sure the motors are offset by at least 100mm.
- (3) For chutes, make sure the motor is installed near the chute's mouth, as shown in the diagram.
- (4) Do not attach the motor directly to the hopper or chute. Instead, weld a base plate to the hopper or chute and bolt the motor to the base plate.
- (5) Make sure the motor's protective circuits, including the ground wire and thermal relay, are completely installed and operational.

Hopper

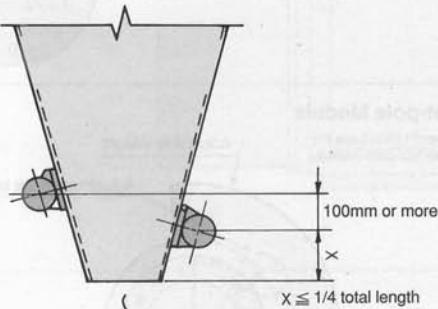

Chute

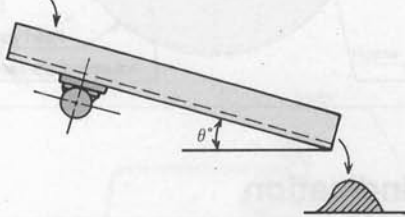

Outer Dimensions of Base Plate

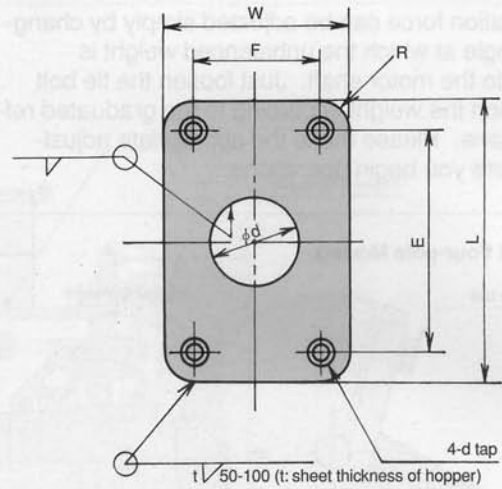

Reference Chart for Base Dimensions

Model	Standard sheet thickness of hopper	Outer thickness of base plate	Outer dimensions of base plate						
			W	L	F	E	D	R	d
RV-042	1.6	9	80	350	30	100	40	30	M6
RV-072D	1.6	12	100	400	40	120	40	30	M8
RV-12E	3.2	16	220	500	150	150	140	30	M12
RV-22D	4.5	16	250	500	90	150	150	35	M12
RV-42E	6	22	200	640	110	190	110	45	M16
RV-72E	9	25	200	640	110	180	110	45	M16
RV-064	3.2	12	150	450	80	120	80	30	M8
RV-14D	4.5	16	160	500	80	150	90	35	M10
RV-24D	6	22	180	560	100	160	100	40	M12
RV-44D	9	25	200	640	110	180	110	45	M16
RV-64	9	25	250	700	140	220	120	50	M20
RV-74D	12	32	250	800	125	240	140	55	M24
RV-154B ₂	19	40	320	900	190	310	190	65	M30



RV-12E



RV-42E



RV-66E

Vibrating Motor Selection Graph (When Used as Feeders)

The graphs below will help you to select the most appropriate unit in both the 50Hz and 60Hz ranges based on the total weight of the feeder and the vibration amplitude that is required.

Find the point where the lines representing the total weight of the feeder and the required vibration amplitude intersect. The slanted line immediately above and to the right of the intersection point represents the recommended model. For example, If your feeder operates at 60Hz, has a total feeder weight of 500kg, and requires a vibration amplitude of 3mm, the recommended model is RV-74D. The graph was calculated on the assumption that two vibrating motors are used.

If only one motor is used, the values given for the vibration amplitude should be reduced by half.

Vibrating motors should always be operated within the amplitude limits (double amplitude) shown on the chart on the right.

• Amplitude Limits (Double Amplitude)

Unit: mm

	50 Hz	60 Hz
Four poles	4.5	3
Six poles	9	6
Eight poles	15	10

• Four- and Eight-pole Models

Values shown are for 60Hz. When operating at 50Hz, it is possible to handle total weights up to 1.44 times the shown values.

*Total weights include the weight of the motor.

• Six poles Models

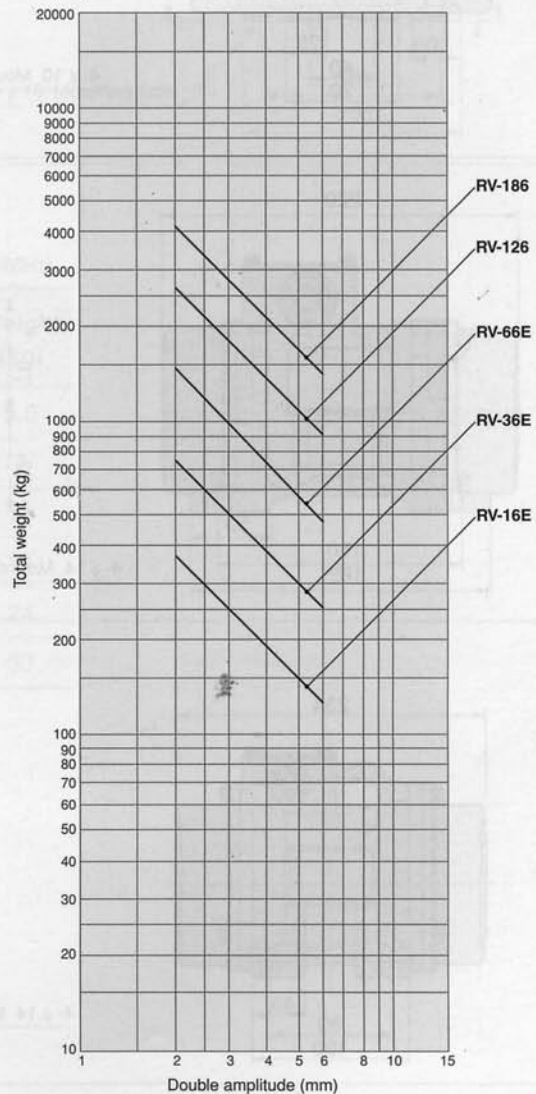
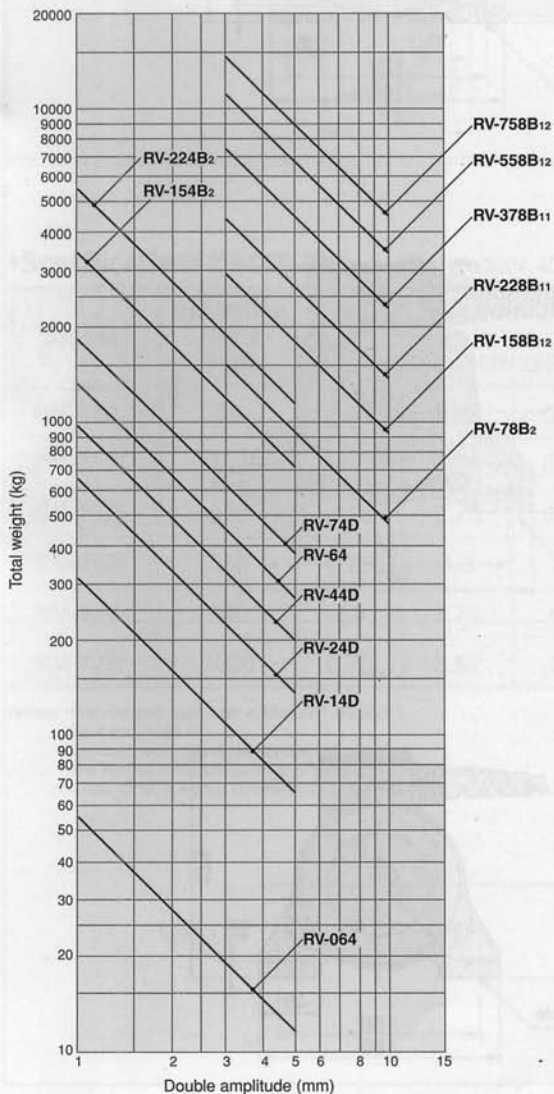

RV Series Vibrating Motors (Two Poles)

RV-042

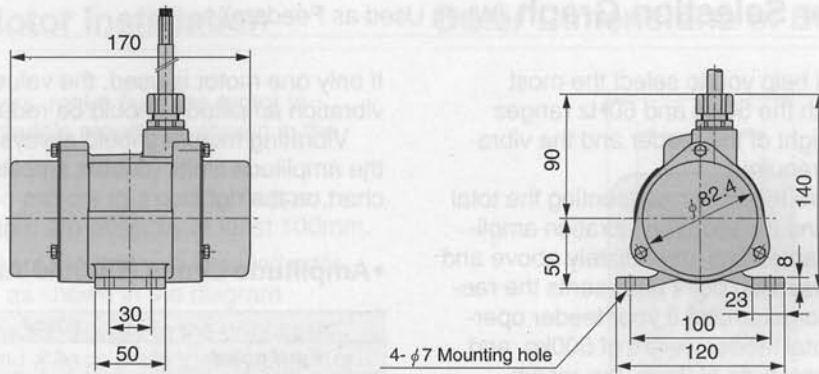

RV-072D

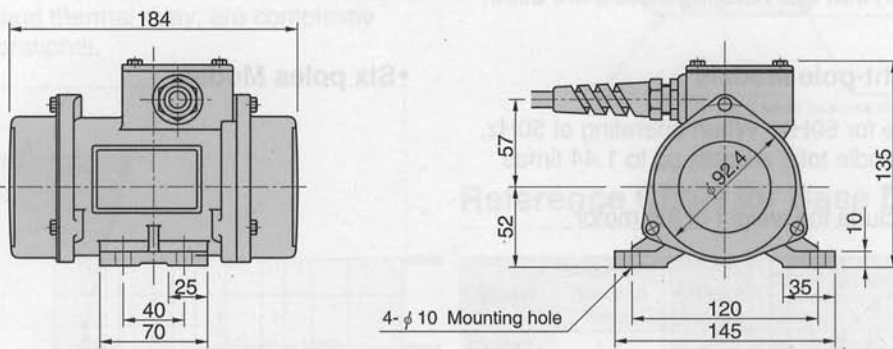

RV-12E

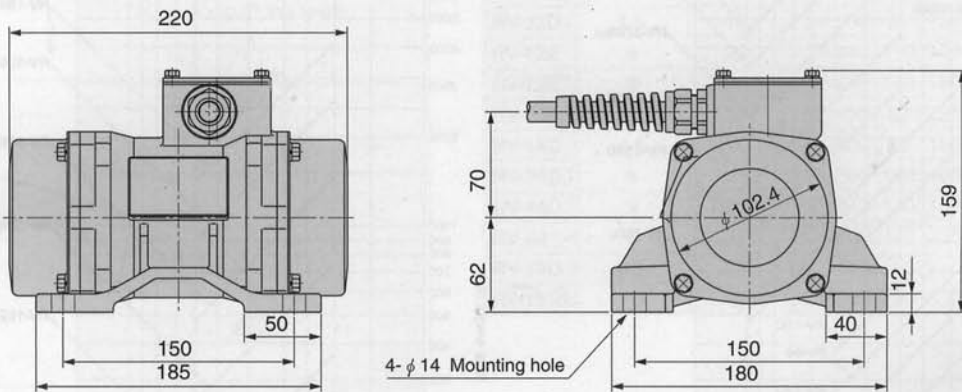

RV-22D

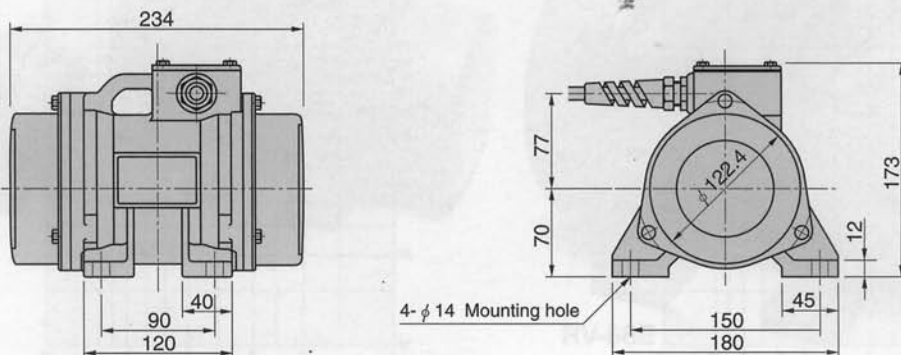

RV-42E

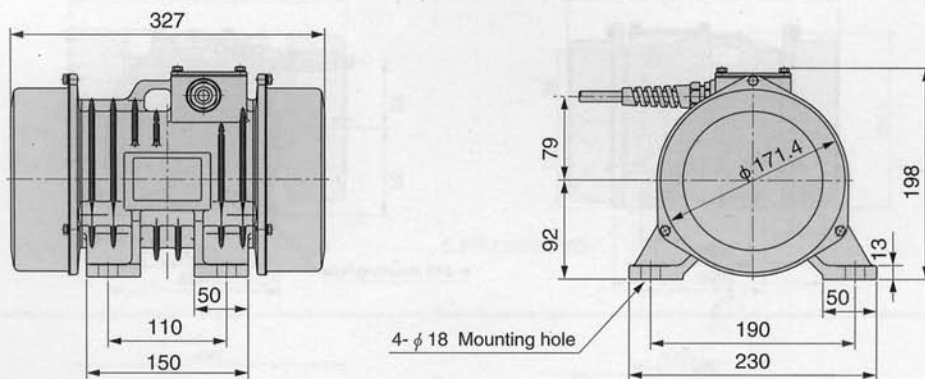

RV-72E

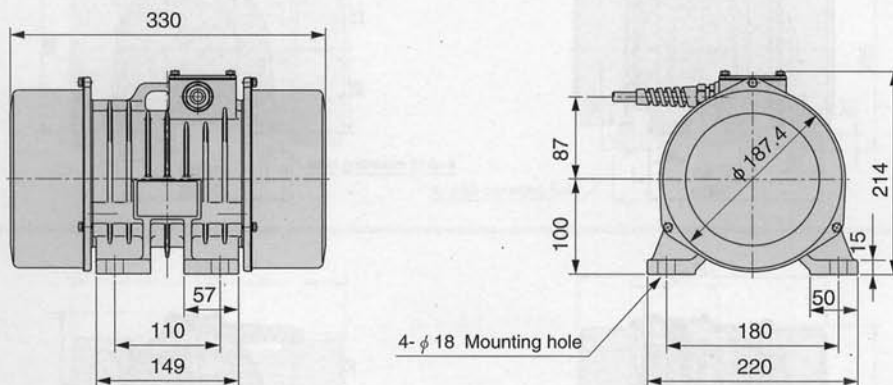

Unit: mm

•Specifications (Continuous rating, 3-phase, 200/220V, 400/440V, 50/60Hz)

Model	Excitation force (kgf)	Output (kW)	Current (A)		Weight (kg)
			200V/50H	220V/60H	
RV-042	50	0.04	0.25	0.23	5.0
RV-072D	100	0.075	0.44	0.40	7
RV-12E	200	0.15	0.75	0.67	11
RV-22D	350	0.25	1.3	1.2	14
RV-42E	600	0.4	1.76	1.6	24
RV-72E	1000	0.75	3.52	3.2	33

- Notes:**
- The standard paint color is Munsell 7.5BG6/1.5.
 - Insulation class: B
 - Special specification apply for outdoor operation.
 - The RV-042 is manufactured only to 200/220V specifications.
 - Cable: 2PNCT, 4-core, 0.75mm² (O.D. 1.1mm), length 2m (green ground wire).

RV Series Vibrating Motors (Four Poles)

RV-064

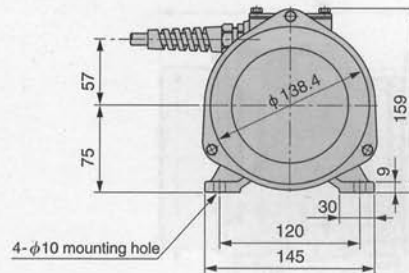
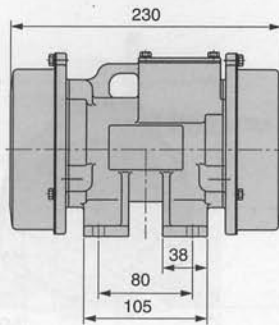

RV-14D

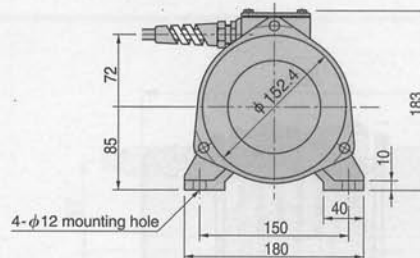
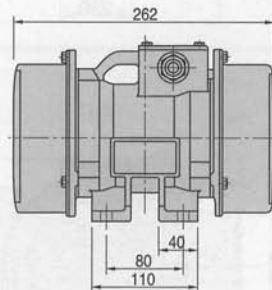

RV-24D

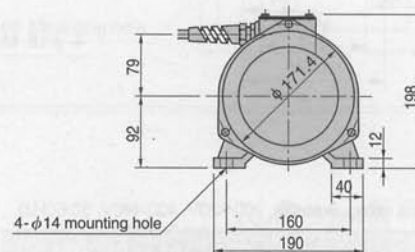
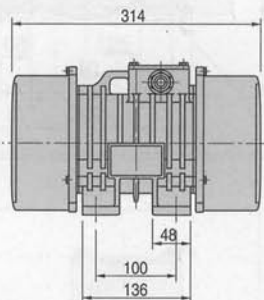

RV-44D

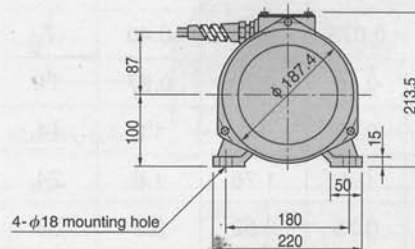
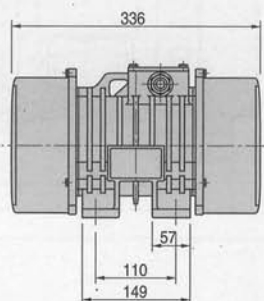

RV-64

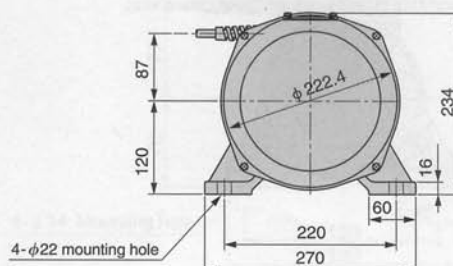
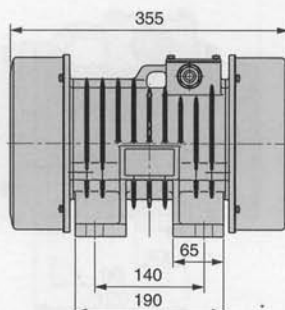

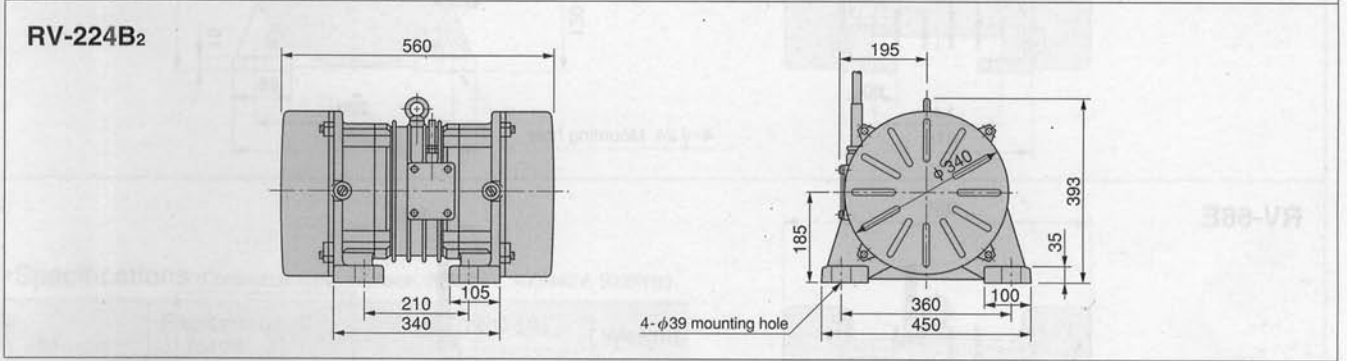
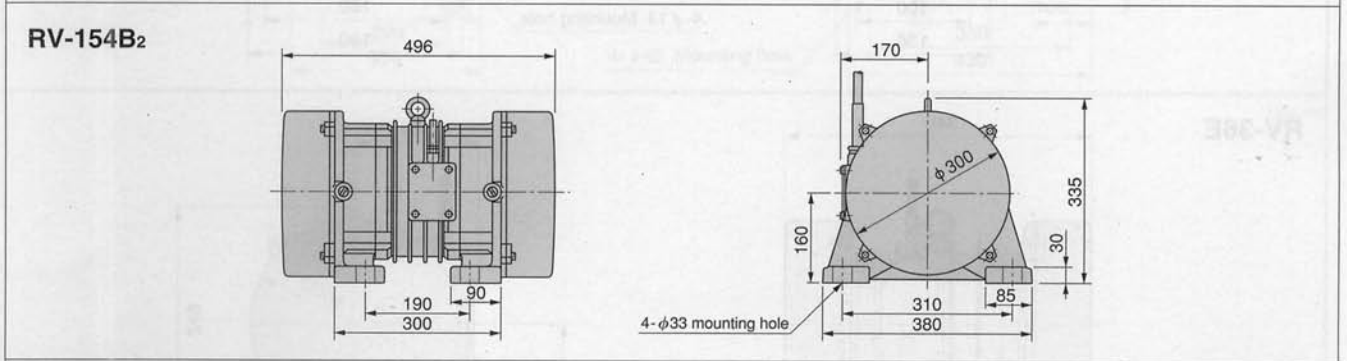
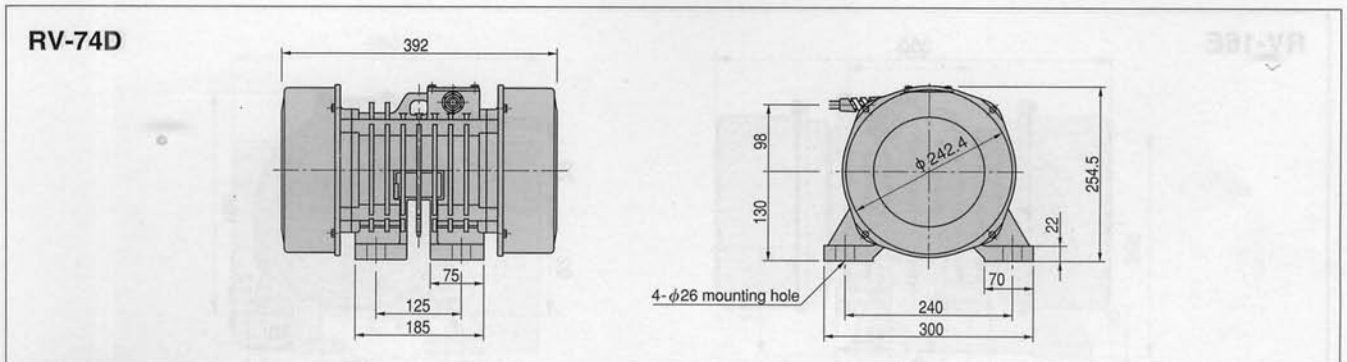

Unit: mm

Specifications (Continuous rating, 3-phase, 200/220V, 400/440V, 50/60Hz)

Model	Excitation force (kgf)	Output (kW)	Current (A)		Weight (kg)
			200V/50H	220V/60H	
RV-064	150	0.065	0.58	0.55	12
RV-14D	300	0.12	0.84	0.74	18
RV-24D	600	0.25	1.6	1.4	26.5
RV-44D	900	0.4	2.1	1.9	36
RV-64	1200	0.6	3.06	2.75	45
RV-74D	1700	0.75	3.6	3.2	66
RV-154B ₂	3200	1.5	6.6	6.0	130
RV-224B ₂	5000	2.2	9.6	8.8	180

- Notes:**
- The standard paint color is Munsell 7.5BG6/1.5.
 - Insulation class: B
 - RV-064~74D are for outdoor operation.
 - Cable: RV-064~74D: 2PNCT, 4-core, 0.75mm²(O.D. 11mm), length 2m (green ground wire).
RV-154B₂: 2PNCT, 4-core, 2.0mm²(O.D. 12.5mm), length 2m (green ground wire).
RV-224B₂: 2PNCT, 4-core, 3.5mm²(O.D. 14.5mm), length 2m (green ground wire).

RV Series Vibrating Motors (Six Poles)

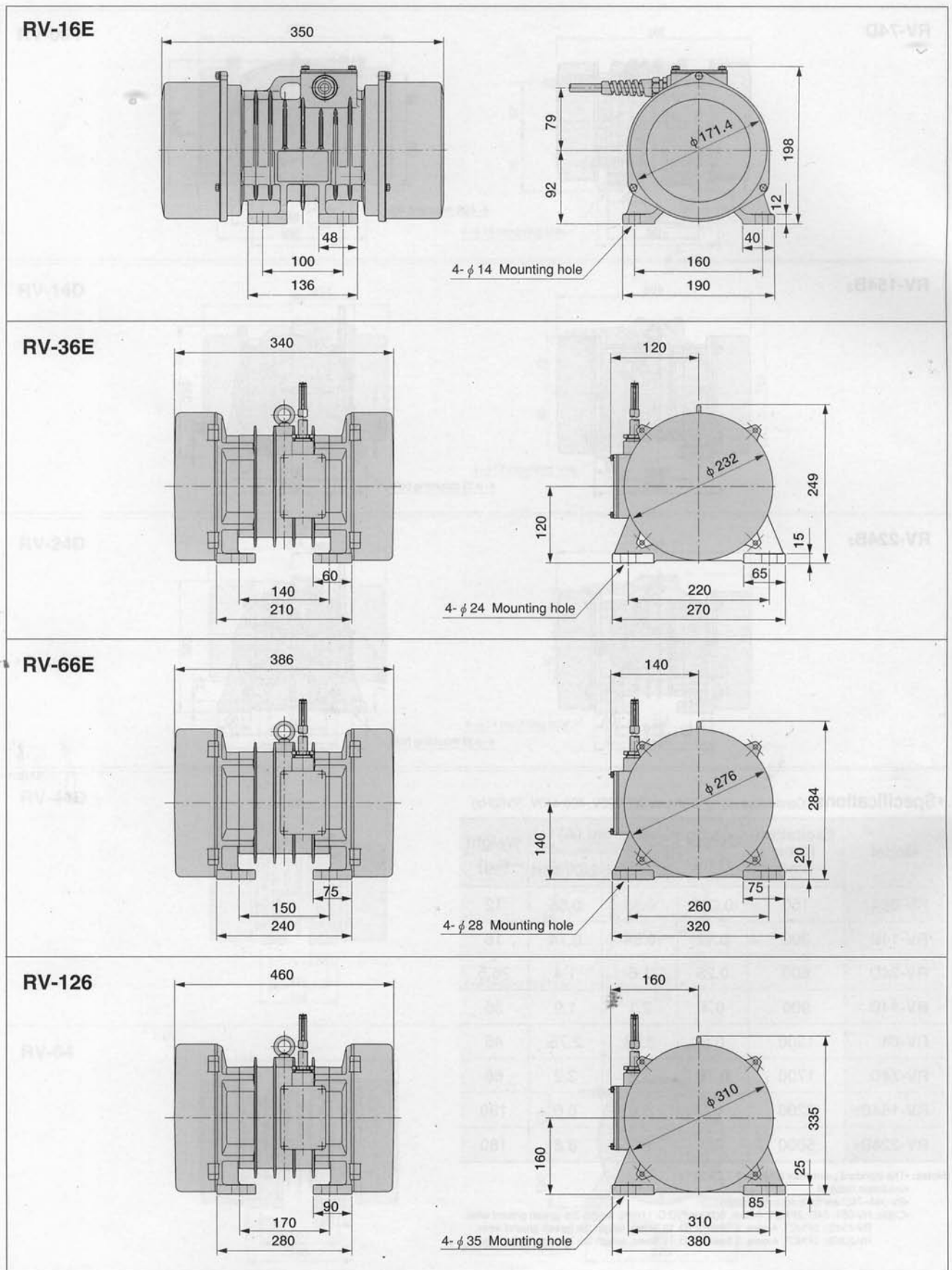

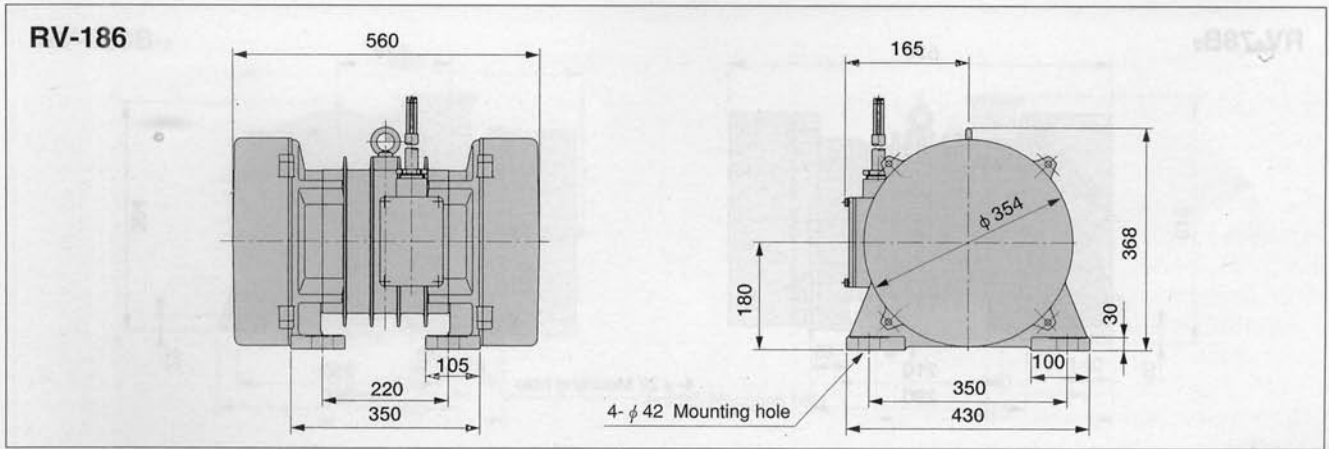

Unit: mm

Specifications (Continuous rating, 3-phase, 200/220V, 400/440V, 50/60Hz)

Model	Excitation force (kgf)	Output (kW)	Current (A)		Weight (kg)
			200V/50H	220V/60H	
RV-16E	300	0.16	1.1	1.0	28.9
RV-36E	600	0.32	2.14	1.94	42
RV-66E	1200	0.6	4.1	3.68	68.2
RV-126	2200	1.2	7.2	6.4	116
RV-186	3400	1.8	10.0	9.0	166

- Notes:**
- The standard paint color is Munsell 7.5BG6/1.5.
 - Insulation class: B
 - RV-16E is for outdoor operation. Others are for indoor operation.
 - RV-126, 186 are dual voltage, 200V or 400V.
 - Cable: RV-16E: 2PNCT, 4-core, 0.75mm²(O.D. 1.1mm), length 2m (green ground wire).
 - RV-36E~RV-126: 2PNCT, 4-core, 1.25mm²(O.D. 1.5mm), length 2m (green ground wire).
 - RV-186: 2PNCT, 4-core, 2.0mm²(O.D. 1.6mm), length 2m (green ground wire).

RV Series Vibrating Motors (Eight Poles)

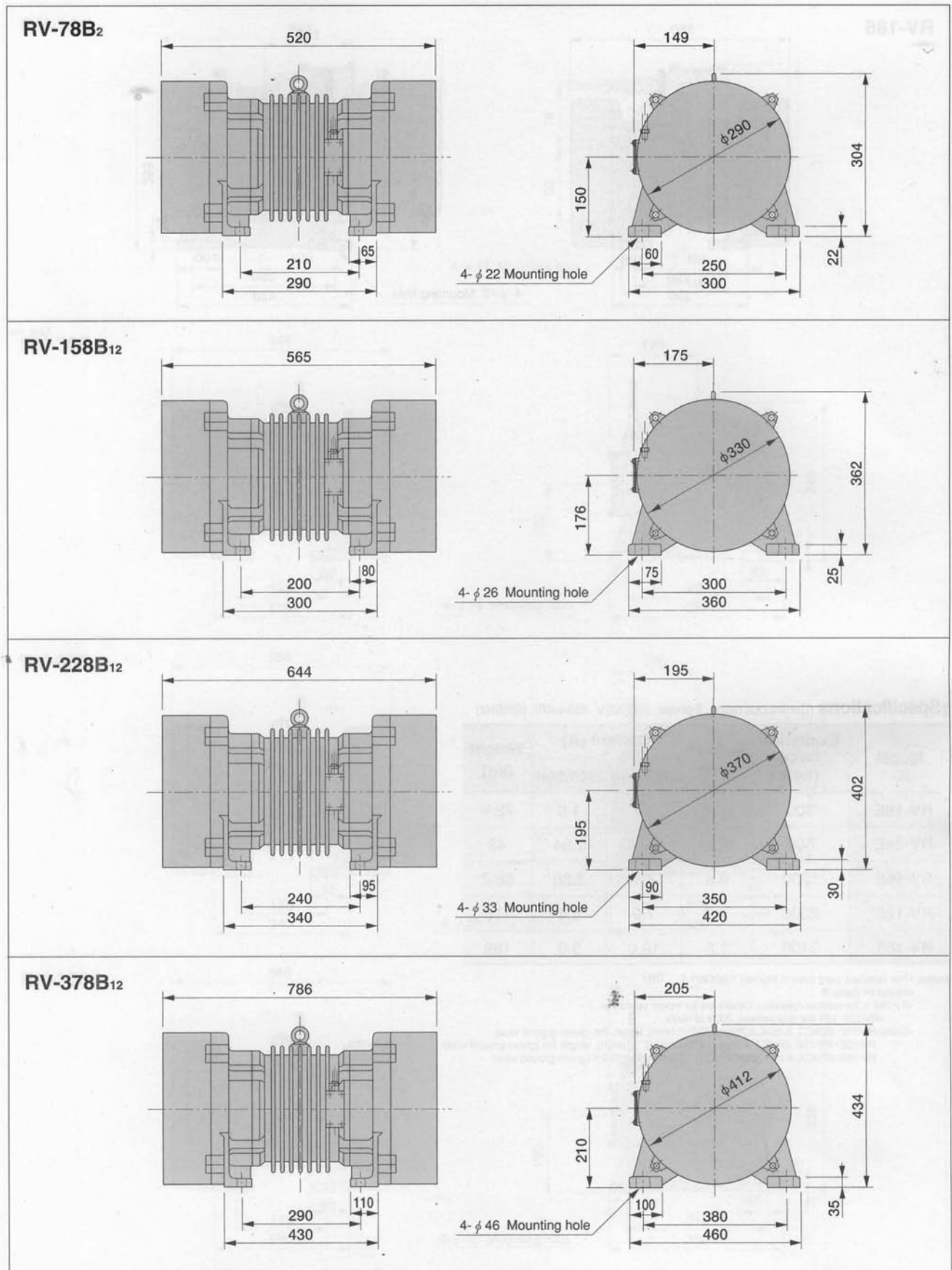

RVXI Series Vibrating Motors

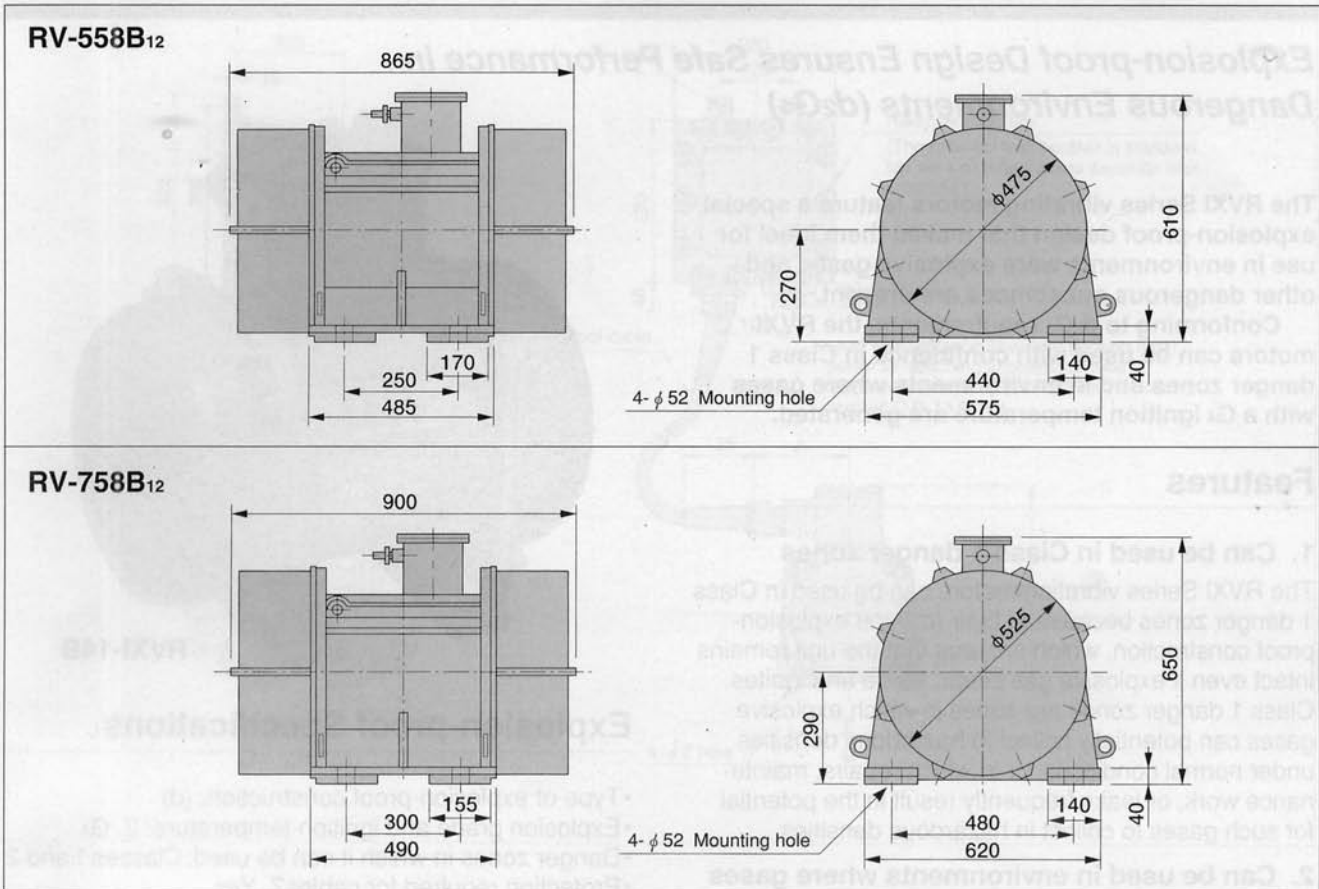

Unit: mm

•Specifications (Continuous rating, 3-phase, 200/220V, 400/440V, 50/60Hz)

Model	Excitation force (kgf)	Output (kW)	Current (A)		Weight (kg)
			200V/50H	220V/60H	
RV-78B ₂	1000	0.75	4.4	4.0	104
RV-158B ₁₂	2000	1.5	9.0	8.0	160
RV-228B ₁₂	3000	2.2	8.0	7.4	260
RV-378B ₁₂	5000	3.7	13.8	12.6	320
RV-558B ₁₂	7500	5.5	15.0	14.0	520
RV-758B ₁₂	10000	7.5	21.0	19.0	650

Notes: •The standard paint color is Munsell 7.5BG6/1.5.

- Insulation class: B
- All models are for indoor operation. Separate specifications apply to models for outdoor operation.
- All models are dual voltage, 200V or 400V.
- Cable: RV-78B₂: 2PNCT, 4-core, 1.25mm² (O.D. 11.5mm), length 2m (green ground wire).
 RV-158B₁₂: 2PNCT, 4-core, 2.0mm² (O.D. 12.5mm), length 2m (green ground wire).
 RV-228B₁₁, 228B₁₂: 2PNCT, 4-core, 3.5mm² (O.D. 15.8mm), length 3m (green ground wire).
 RV-558B₁₂, 758B₁₂: 2PNCT, 4-core, 5.5mm² (O.D. 17.4mm), length 3m (green ground wire).